



PRODUCT SELECTION GUIDE

- ◎ Rail-Mounted Intelligent Measurement & Control Instrument
- ◎ AI Temperature Controller/Regulator
- ◎ Paperless Recorder/Human-Machine Interface

CONTENTS

Technical Parameters	01
Common Module Functions	02
Table of Input Specification (firmware version 9.3)	04
Instrument Dimensions	05
AI-8 series Single-loop High Performance Artificial Intelligence (AI) Controller / Temperature Controller	06
AI-8 series Cascade High Performance Multi-function Temperature Controller / Regulator	11
AI-8XXX Multi-loop High-Performance PID Controller	16
(1) AI-88X8 Series High-Precision Multi-Function PID Controllers, with optional FA high-reliability grade products suitable for the semiconductor industry.	17
(2) AI-86X8 Series Multi-Function PID Controller, featuring cascade control algorithms and I/O programming capabilities	19
(3) AI-8XXX Series Universal PID Controller for multi-loop and low-cost requirements	20
AI-7 Series MultiLoop CostEffective Measurement and Control Instruments	25
AI-7 Series Multi-Loop Measurement and Alarm Instruments	27
AI Series MultiChannel PID Temperature Controller	30
AI-208/218 Economy Intelligent Temperature Controller	32
AI-226 Economical Multi-Function Intelligent Temperature Controller	35
AI-211/500/501/700/701 Universal Single-Channel Display Alarm Instrument	37
AIJK Series Phase-Shift Trigger	43
AI-601/6010/6011 Series Power Meters	44
AI Series DIN Rail Mounted Digital Input / Output Module	47
AI-3150/3170/3190 Series Split Paperless Recorder	52
AI-3270/3290 Series True-color Touch Screen HMI	53
AI-5500/5600 Handheld High-Precision Digital Thermometers	59
AIJK Series Phase Angle Triggers	60
SSR Solid State Relay	62
Transmitter Current Input Isolating Safety Barrier	63
DC Signal Input Isolating Safety Barrier	65
DC Signal Output Isolating Safety Barrier	67
Thermocouple Input Isolating Safety Barrier	69
Thermocouple Input Isolating Safety Barrier	71
General Purpose Current Vector Inverter	73

Technical Parameters

The following are the main technical parameters for the new-generation AI-8 high-performance multi-function temperature controller/regulator. Parameters for other series models may be reduced. For any questions, please refer to the product manual or consult technical personnel.

> Input Specifications

Thermocouple: K, S, R, E, J, T, B, N, WRe3-WRe25, WRe5-WRe26, etc.

RTD: Cu50, Pt100, Ni120

Linear Voltage: 0-5V, 1-5V, 0-10V, 0-1V, 0-75mV, 0-20mV, -5 to +5V, -1 to +1V, -20mV to +20mV, etc.

Linear Current: 0-10mA, 0-20mA, 4-20mA, etc.

Extended Specification: While retaining the above input types, allows users to define one additional custom input type.

> Measurement Range

K(-200~+1300°C)、S(-50~+1700°C)、R(-50~+1700°C)、T(-200~+350°C)、E(-200~+1000°C)、J(-200~+1200°C)、B(200~1800°C)、N(-100~+1300°C)、WRe3-WRe25(0~2300°C)、WRe5-WRe26(0~2300°C)、Cu50(-50~+150°C)、Pt100(-200~+800°C)、Ni120(-50~+270°C)

Linear Input: -9990 to +32000 (userdefinable)

> PV Accuracy

Class 0.05~0.1/Class 0.1/Class 0.15/Class 0.2/Class 0.25/Class 0.3 (Note: For thermocouple inputs, external Cu50 or PT100 may be selected for coldjunction compensation. Internal compensation will introduce an additional ± 1 °C compensation error. Class 0.05 applies to highend models with input types including PT100, S and Btype thermocouples, and mV inputs that support 0.05 level accuracy. Instruments with Class 0.1 or 0.05 accuracy can optionally use built in PT100 coldjunction compensation, eliminating the need for external compensation components while still meeting 0.1/0.05 class accuracy requirements for thermocouples. In this case, the instrument cannot select a thermistor as the primary input type.)

> Control Cycle

Adjustable from 0.1 to 300.0 seconds

> Refresh Rate

Adjustable from 60 ms ~ 960 ms (Refresh rate corresponds to the update rate when the digital filter parameter FILt = 0. If FILt is 1 or higher, the filtering routine will increase the refresh time by more than double. Also, higher refresh rates lead to greater input noise and reduced anti interference capability; input wiring must be properly shielded and maintain sufficient distance from high power circuits.)

> Control Modes

On Off control mode (adjustable hysteresis)

AI artificial intelligence control, incorporating fuzzy logic PID and autotuning capabilities

Standard PID control

Cascade control (AI8x9 series)

> Output Specifications

Relay contact output (NO + NC): 250 VAC/2 A or 30 VDC/2 A

Solidstate relay (SSR) noncontact switch output (NO or NC): 100-240 VAC/0.2 A (continuous);

2 A (20 ms instantaneous, repeat cycle 5 s)

SSR voltage output: 12 VDC/30 mA (for driving SSR solidstate relays)

Triac trigger output: Capable of triggering 5–500 A triacs, two antiparallel connected SCRs, or thyristor power modules

Linear current output: 0–20 mA or 4–20 mA definable (Energysaving module maximum output voltage ≥ 5.5 V;

Highvoltage module output voltage ≥ 10.5 V)

➤ Communication

Interface: RS485, RS232, RJ45

Communication Baud Rate: 1200 bps ~ 28,800 bps

Communication Protocol: AIBUS, MODBUS-RTU, TCP and EtherCAT

➤ Isolation Withstand Voltage

Between power supply, relay contacts, and signal terminals: ≥ 2300 V

Between isolated low-voltage signal terminals: ≥ 600 V

➤ Power Supply 100–240 VAC or DC, -15% to +10%, 50–60 Hz; or 24 VDC, -15% to +10%

➤ Power Consumption

≤ 0.3 W (including CPU, measurement, display, and communication; excludes any output or external power supply load)

➤ Operating Environment

Temperature: -10 °C to $+60$ °C Humidity: ≤ 90 % RH

Common Module Functions

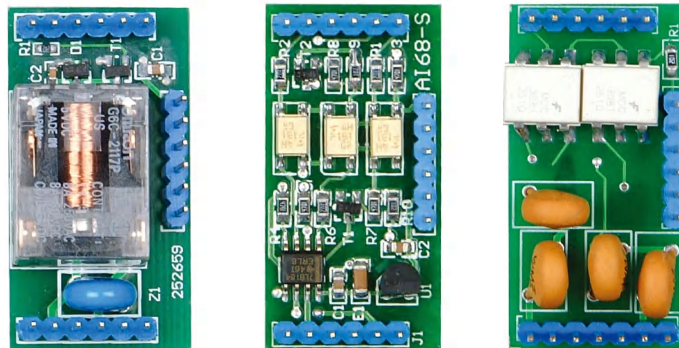

Communication Interface Module

- S** Optically isolated RS485 communication module (using the instrument's internal 12V isolated power supply)
- S1** Optically isolated RS485 communication module (using the instrument's internal 24V isolated power supply)
- S2** Optically isolated RS485 communication module (suitable for D, D7, D71 models)
- S4** Communication module with its own isolated power supply (does not consume the instrument's internal power supply)
- S6** RS485 optically isolated communication module supporting standard MODBUS-RTU protocol (using the instrument's internal 12V isolated power supply)
- S7** RS485 optically isolated communication module supporting standard MODBUS-RTU protocol (using the instrument's internal 24V isolated power supply)
- R** RS232 communication / printing module

Analogue Output Module

- X3** Optically isolated current output module (using the instrument's internal 12V isolated power supply)
- X5** Optically isolated current output module with its own isolated power supply (does not consume the instrument's internal isolated power supply)
- X6** Dual-channel high-precision linear current output module (using the instrument's internal 12V isolated power supply)

Voltage Output Module (for powering external sensors / low-power devices)

V5/V10/V12/V24 Isolated 5V, 10V, 12V, 24V DC voltage output (using the instrument's internal 24V isolated power supply)

Digital Output Module

- G1** Energy-saving non-isolated SSR driving voltage output module (5V/30mA)
- G2** Dual-channel energy-saving non-isolated SSR driving voltage output module (5V/30mA)
- G3** Three-channel energy-saving non-isolated SSR driving voltage output module (5V/30mA)
- G** Solid-state relay driving voltage output module (12V/30mA)
- G5** Dual-channel solid-state relay driving voltage output module (12V/30mA)
- G51** Dual-channel isolated NPN transistor output, capable of externally connecting 5-24VDC to drive solid-state relays or intermediate relays, with a driving current of 100mA per channel (suitable for D71 model)
- G6** Three-channel solid-state relay driving voltage output module (12V/30mA) (suitable for D71 model)
- G61** Three-channel isolated NPN output module
- G62** Three-channel isolated PNP output module
- L0** Large-size, high-capacity relay contact switch output module (suitable for alarms)
- L1** Large-size, high-capacity relay contact switch output module (suitable for control)
- L21** Small-size relay contact switch output module (suitable for alarms)
- L3** Two-channel large-size, high-capacity relay contact switch output module
- L33** Single normally open small-size relay contact switch output module (suitable for alarms, fits D model)
- W1** "Burn-proof" type thyristor non-contact normally open switch output module
- W2** "Burn-proof" type thyristor non-contact normally closed switch output module
- W5** "Burn-proof" type thyristor non-contact dual-channel normally open output

* For more functional modules, please consult the manufacturer directly.

Thyristor Trigger Output Module

- K1** "Burn-proof" single-channel zero-crossing trigger output module
- K3** "Burn-proof" three-channel thyristor zero-crossing trigger output module
- K50/K60** "Burn-proof" single-channel thyristor phase-angle trigger output module
- K51** "Burn-proof" single-channel thyristor phase-angle trigger output module for inductive loads
- K9** "Burn-proof" direct three-phase three-wire thyristor phase-angle trigger output module

Input (Analog and Digital) Modules

- J0** 1-channel three-wire RTD input or 1-channel thermocouple + 1-channel two-wire RTD input module
- J1** 2-channel thermocouple input module
- J2** 2-channel two-wire RTD input module
- J3** 2-channel voltage input module
- J31** 2-channel 0-10 V voltage input module
- J4** 2-channel current input module

- J5/J51 2-channel transmitter input module (with 24V loop power supply)
 I2 Frequency / external PNP digital input interface module
 I21 Frequency / external NPN digital input interface module
 I22 Two-channel NPN digital input interface module (suitable for D71 model)
 I3 1-channel 0~5V/1~5V voltage input interface module
 I31 1-channel 0~10V voltage input interface module
 I4/I44 1-channel 0~20mA/4~20mA current input interface module
 I5 2-channel digital input module
 I5A 1-channel 0~5A DC current input module
 I7 1-channel 0~5A AC current input module
 I8 1-channel 0~500V AC voltage input module
 I20 1-channel 0~20V DC voltage input module
 I50 1-channel 0~50V DC voltage input module
 I100 1-channel 0~100V DC voltage input module
 I200 1-channel 0~200V DC voltage input module
 I50 1-channel 0~500V DC voltage input module
 I1000 1-channel 0~1000V DC voltage input module
 I9 CT measurement module, used with CT current transformers for heater break alarm

Note: The input code for modules I5A~I1000 is 16.

Table of Input Specification (firmware version 9.3)

The new-generation AI-8 series of artificial intelligence regulators / temperature controllers allow free configuration of thermocouple, RTD, and linear voltage (current) inputs. The thermocouple inputs also feature external compensation functionality, along with user-defined indexing tables and multi-point calibration capabilities, enabling adaptation to almost all special input requirements.

Code	Input Specification	Code	Input Specification	Code	Input Specification
0	K	15	4~20mA (Pluggin I44/I45 in MIO slot)	28	0~20mV Voltage Input
1	S	16	0~20mA (Pluggin I44/I45 in MIO slot)	30	0~60mV Voltage Input
2	R	17	K (0~300.00°C)	31	0~1V Voltage Input
3	T	18	J (0~300.00°C)	32	0.2~1V Voltage Input
4	E	19	Ni120	33	1~5V Voltage Input
5	J	20	Cu50	34	0~5V Voltage Input
6	B	21	Pt100	35	-20~+20mV Voltage Input
7	N	22	Pt100(-80~+300.00°C)	37	-5~+5V Voltage Input
8	WRe3-WRe25	25	0~75mV Voltage Input	39	15~75mV
9	WRe5-WRe26	26	0~100Ω Resistor Input	42	0~10V Voltage Input
10	User defined extended specification	27	0~400Ω Resistor Input	43	2~10V Voltage Input
12	F2 Infrared Pyrometer			44	-10~+10V Voltage Input
			

Instrument Dimensions

The AI series instruments support either plug-in modules or solder-in modules. For the following model codes, if the last digit is not 1, it indicates a plug-in module; if the last digit is ****1****, it indicates a solder-in module.

For example:

- A9 represents an instrument with plug-in modules.
- A91 represents an instrument with solder-in modules.

Note: Some products, such as the AI-2 series, only support solder-in modules by default.

A /A1 A2 /A21 A5 /A51 A9/A91 B/B1



C3/C31 D D21 / D61 / D62

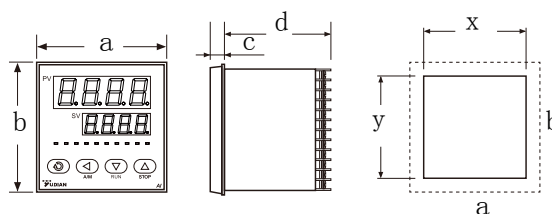

E /E1 E2 /E21 E3 /E31 E9 /E91 F/F1



Panel	outer(mm)				Opening(mm)	
	a	b	c	d	x	y
A/A1/A2/A21/ A5/A51/A9/A91	96	96	8	72	92	92
B/B1	160	80	8	72	152	76
C3/C31	80	160	8	72	76	152
D	72	72	8	70	68	68
D21	48	48	9	79	45	45
D61	48	48	9	79	45.5	45.5
D62	48	48	9	67	45.5	45.5
E/E1/E2/E21/ E3/E31/E9/E91	48	96	8	71	45	92
F/F1	96	48	8	71	92	45
P5	145	105	6	94	135	96
P7	203	150	6	34	192	139
P9	231	170	6	32	221	160

P5 / P7 / P9



D5 D7 / D71 E5 / E51 E81 / E85

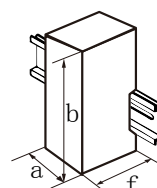

Panel	outer(mm)		
	a	b	f
D5	22.5	100	112
D7 / D71	22.5	100	112
E5 / E51	44.5	93	81
E81 / E85	45	96	18

AI-8 series Single-loop High Performance Artificial Intelligence (AI) Controller / Temperature Controller

AI									Description
Model	888								AI-8 Series Single-Loop High-Performance AI Regulator / Temperature Controller, Class 0.1 Accuracy For high-precision instrument model 888, the suffix J0 (indicating RTD) or J1 (indicating thermocouple) is added to the model number to differentiate inputs. Note: J1 input has an internal soldered PT100 to improve accuracy but is limited to thermocouple input only. (J0/J1 note appears after dimensions.)
	868								AI-8 Series Single-Loop High-Performance AI Regulator / Temperature Controller, $\pm 0.15\%$ of displayed value.
	858								AI-8 Series Single-Loop High-Performance AI Regulator / Temperature Controller, $\pm 0.2\%$ of displayed value.
	838								AI-8 Series Single-Loop High-Performance AI Regulator / Temperature Controller, $\pm 0.25\%$ of displayed value.
	828								AI-8 Series Single-Loop High-Performance AI Regulator / Temperature Controller, $\pm 0.3\%$ of displayed value.
	826								$\pm 0.3\%$ of displayed value compared to model 828, only supports single-segment program operation and does not support external setpoint input, valve position feedback input, or valve motor control functions. Other functions are similar to model 828.
Panel Dimension (WxH)	A								Panel Dimensions 96×96mm
	A2								Panel Dimensions 96×96mm with Light Bar
	A5								Panel Dimensions 96×96mm, Dual 5-Digit Display with Light Bar (available for instruments with accuracy \geq Class 0.2)
	A9								Panel Dimensions 96×96mm, Two Rows of 5-Digit Display + Third Row of 4-Digit Display (available for instruments with accuracy \geq Class 0.2)
	B								Panel Dimensions 160×80mm
	C3								Panel Dimensions 80×160mm, Three Rows of 4-Digit Display
	D								Panel Dimensions 72×72mm (no ALM and MIO ports; modules optional)
	D61								Panel Dimensions 48×48mm, 12 Terminal Connections (no ALM and MIO ports; modules optional)
	E								Panel Dimensions 48×96mm
	E2								Panel Dimensions 48×96mm with Light Bar
	E3								Panel Dimensions 48×96mm, Three Rows of 4-Digit Display
	E5								DIN Rail Mounting, Width 45mm, No Built-in Display, External E85 Display Unit
E9								Panel Dimensions 48×96mm, Two Rows of 5-Digit Display + Third Row of 4-Digit Display (available for instruments with accuracy \geq Class 0.2)	
F								Panel Dimensions 96×48mm	
Multi-I/O (MIO)	I2/I5								Digital Input Module for Et Event Input Can be configured for functions such as Start/Stop, Setpoint/PID parameter switching, Direct/Reverse action switching, Manual/Auto control switching, and Run/Stop. (I2 is single-channel, I5 is dual-channel.)
	I45								0-20mA/4-20mA Current Input Module with 24V Loop Power Supply
	I9								CT Measurement Module for Heater Break Alarm
	V*								V24, V12, V10 Modules: 24VDC, 12VDC, 10VDC Power Supply Modules

Main Output (OUTP)	L1				Large-Size Single-Channel Relay Output Module, Capacity 250VAC/2A
	L3				Dual-Channel Relay Output Module, Two Sets of Normally Open Contacts, Capacity 250VAC/2A
	G				Solid-State Relay Drive Voltage Output Module (DC12V/30mA)
	W1/W2				Thyristor Non-Contact Switch Output Module (W1 is normally open, W2 is normally closed)
	X3/X51				Optically Isolated Linear Current Output Module (X3 uses instrument power supply, X51 has its own isolated power supply)
	K1/K3				Thyristor Zero-Crossing Trigger Output Module (K1 is single-channel, K3 is three-channel; K3 occupies the MIO port)
	K50/ K60				Thyristor Phase-Angle Trigger Output Module (K50 for 220V, K60 for 380V voltage)
Alarm (ALM)	L0				Large-Size Single-Channel Relay Output Module, Capacity 250VAC/2A
	L3				Dual-Channel Relay Output Module, Two Sets of Normally Open Contacts, Capacity 250VAC/2A
	G				Solid-State Relay Drive Voltage Output Module (DC12V/30mA)
	W1/W2				Thyristor Non-Contact Switch Output Module (W1 is normally open, W2 is normally closed)
Auxiliary (AUX)	L1				Large-Size Single-Channel Relay Output Module, Capacity 250VAC/2A
	L0				Large-Size Single-Channel Relay Output Module, Capacity 250VAC/2A
	L3				Dual-Channel Relay Output Module, Two Sets of Normally Open Contacts, Capacity 250VAC/2A
	G				Solid-State Relay Drive Voltage Output Module (DC12V/30mA)
	X3/ X51				Optically Isolated Linear Current Output Module (X3 uses instrument power supply, X51 has its own isolated power supply)
	R				RS232 Communication Interface (uses instrument's internal 12V power supply)
Communication (COMM)	I2				Digital Input Module for Et Event Input Can be configured for functions such as Start/Stop, Setpoint/PID parameter switching, Direct/Reverse action switching, Manual/Auto control switching, and Run/Stop. (Single-channel.)
	S				Optically Isolated RS485 Communication Interface Module (occupies the first set of 12V isolated power supply)
	S2				Optically Isolated RS485 Communication Interface Module (occupies the second set of 12V isolated power supply)
	X3				Optically Isolated Programmable Linear Current Output Module (occupies the first set of 12V isolated power supply)
Power					Default Power Supply: 100-240VAC
				-24VDC	Power Supply: 24VDC

AI									Description
Model	888								AI-8 Series Single-Loop High-Performance AI Regulator / Temperature Controller, $\pm 0.1\%$ of displayed value. For high-precision instrument model 888, the suffix J0 (indicating RTD) or J1 (indicating thermocouple) is added to the model number to differentiate inputs. Note: J1 input has an internal soldered PT100 to improve accuracy but is limited to thermocouple input only. (J0/J1 note appears after dimensions.)
	868								AI-8 Series Single-Loop High-Performance AI Regulator / Temperature Controller, $\pm 0.15\%$ of displayed value.
	858								AI-8 Series Single-Loop High-Performance AI Regulator / Temperature Controller, $\pm 0.2\%$ of displayed value.
	838								AI-8 Series Single-Loop High-Performance AI Regulator / Temperature Controller, $\pm 0.25\%$ of displayed value.
	828								AI-8 Series Single-Loop High-Performance AI Regulator / Temperature Controller, $\pm 0.3\%$ of displayed value.
	826								$\pm 0.3\%$ of displayed value., compared to model 828, only supports single-segment program operation and does not support external setpoint input, valve position feedback input, or valve motor control functions. Other functions are similar to model 828.
Panel Dimension (WxH)	D71								DIN rail mounting, width 22.5mm, with built-in display, bus-type power supply and communication.
Multi-I/O (MIO)	I2/I22/I5								Digital Input Module, used for Et event input. Configurable functions include: Run Start/Stop, Setpoint/PID Parameter Switching, Direct/Reverse Action Switching, Manual/Automatic Control Switching, and Run/Stop (I2 is single-channel; I22/I5 are dual-channel).
	I9								CT Measurement Module, used for heater break alarm.
	V*								V12 and V10 Modules: 12VDC and 10VDC power supply modules, respectively.
Main Output (OUTP)	L1								Large-Size Single-Channel Relay Output Module, Capacity 250VAC/2A
	L3								Dual-Channel Relay Output Module, Two Sets of Normally Open Contacts, Capacity 250VAC/2A
	G								Solid-State Relay Drive Voltage Output Module (DC12V/30mA)
	W1/W2								Thyristor Non-Contact Switch Output Module (W1 is normally open, W2 is normally closed)
	X3/X56								Optically Isolated Linear Current Output Module (X3 uses instrument power supply, X56 has its own isolated power supply)
	K1								Thyristor Zero-Crossing Trigger Output Module (K1 is single-channel)
	K50/K60								Thyristor Phase-Angle Trigger Output Module (K50 for 220V, K60 for 380V voltage)
Alarm (ALM)	L21								Compact single-channel relay output module, capacity 250VAC/1A.
	L3								Dual-Channel Relay Output Module, Two Sets of Normally Open Contacts, Capacity 250VAC/2A
	G								Solid-State Relay Drive Voltage Output Module (DC12V/30mA)
	W1/W2								Thyristor Non-Contact Switch Output Module (W1 is normally open, W2 is normally closed)

Auxiliary (AUX)	L21		Compact single-channel relay output module, capacity 250VAC/1A.
	G		Solid-State Relay Drive Voltage Output Module (DC12V/30mA)
	X3/ X56		Optically isolated linear current output module (X3 uses instrument power supply, X56 has its own isolated power supply)
Communication (COMM)		S2	Pre-installed S2 module, optically isolated RS485 communication interface
Power		-24VDC	Default power supply: 24VDC
		-220VAC	Customized power supply: 100-240VAC

Convertor

AI-EtherCAT	AI-EtherCAT8	Support
	AI-EtherCAT16	Support
	AI-EtherCAT32	NOT Support
AI-ModbusTCP	AI-ModbusTCP1	Support
	AI-ModbusTCP2	Support
	AI-RTU-ModbusTCP1	NOT Support
	AI-RTU-ModbusTCP2	NOT Support

Note:

For the AI-8 series single-loop high-performance AI regulator / temperature controller, when selecting different types of communication converters, the corresponding communication protocol must be set (via the AFC parameter):

When communicating with the AI-EtherCAT converter, the instrument must be set to ModbusRTU mode (set the AFC parameter to 0).

When communicating with the AI-ModbusTCP converter, the instrument must be set to AIBUS mode (set the AFC parameter to 1).

Considerations on model selection:

- The AI-8 series offers various panel sizes. However, when selecting the D series panel-mounted or rail-mounted instruments, due to space constraints or limited terminal counts, the number of installable modules may be less than the standard quantity, potentially restricting certain functions. Before finalizing your selection, please carefully review the relevant product manual or consult with our technical support team.
- A suffix of 1 in the panel size code indicates soldered-in modules. Instruments with soldered-in modules have all internal modules soldered. A panel size code without a "1" suffix indicates plug-in modules. As product versions evolve, some simpler, less prone to damage, or less frequently used modules may be replaced with more compact and resource-efficient soldered-in modules. Commonly used module positions, such as the main output OUP and AUX, retain plug-in module compatibility.
- The instrument internally provides two sets of 12V power supplies that are isolated from the main circuit for module use.
- Modules using the first 12V power set: X3, X31, X305, S, R, S6.
- Modules using the second 12V power set: X2, S2, I45.
- (Except for the special case of size D61, which can be configured with X3S.)
- Typically, only one module per power set can be installed in a single instrument. If three or more power-consuming modules are required, replace X3 or X2 with isolated-loop modules like X51.
- D panel instruments do not have an MIO port. The COMM port and ALM port share the same output channel. If an RS485 communication module is installed, the instrument will not have an ALM port. If alarm functionality is needed, an alarm output module can be added to the AUX port.
- D61 panel instruments have no MIO or ALM ports and feature 3 soldered-in modules (OUP, AUX, COMM).
- D7/D71 panel instruments use plug-in bus terminals for power and communication wiring.
- D7 has plug-in modules for OUP and AUX, and a soldered COMM module.

12. D71 uses all soldered modules, with the same module count as larger panel-mounted instruments, ensuring full compatibility with all functions of full-size instruments.
13. Regarding auxiliary input (MIO): Yudian instruments natively support direct input of various signals such as thermocouples and RTDs. For other input types, dedicated input modules can be selected—for example, the I45 module for two-wire transmitters, the I7 module for 0-5A AC, etc.
14. Regarding voltage output modules (V*): Yudian instruments can provide power supply modules such as 24VDC, 12VDC, and 10VDC to power external devices. These can be installed in any available module slot, but it is generally recommended to install them sequentially in vacant MIO, AUX, and COMM positions.
15. Instrument models with five-digit displays (A5, A51, A9, A91, E9, E91) are suitable for instruments with accuracy class 0.2 or higher. Models with accuracy class 0.3 or 0.25 are not available in these display configurations.

Example of Model Selection:

AI-858 A I45 G L3 L0 S
 ① ② ③ ④ ⑤ ⑥ ⑦

- ① The main unit model is AI-858, a high-performance multifunctional temperature controller/regulator with Class 0.2 accuracy and a 5-year warranty.
- ② The unit features Type A housing with a 96×96 mm panel and 20 wiring terminals.
- ③ The multi-I/O input (MIO) is equipped with the I45 module, providing 420 mA current input with 24 V loop power supply.
- ④ The main output (OUTP) uses a solidstate relay driving voltage module, rated at 12 VDC / 30 mA.
- ⑤ The alarm (ALM) is equipped with the L3 module, offering two normallyopen alarm outputs.
- ⑥ The auxiliary output/alarm (AUX) is equipped with the L0 module, providing one alarm output with both normallyopen and normallyclosed contacts.
- ⑦ The communication (COMM) is fitted with a communication module, indicating that the instrument supports RS485 communication.

Wire Diagram

Note: Due to technical upgrades or special orders, if the wiring diagram included with the instrument differs from this selection manual, please follow the wiring diagram provided with the instrument.

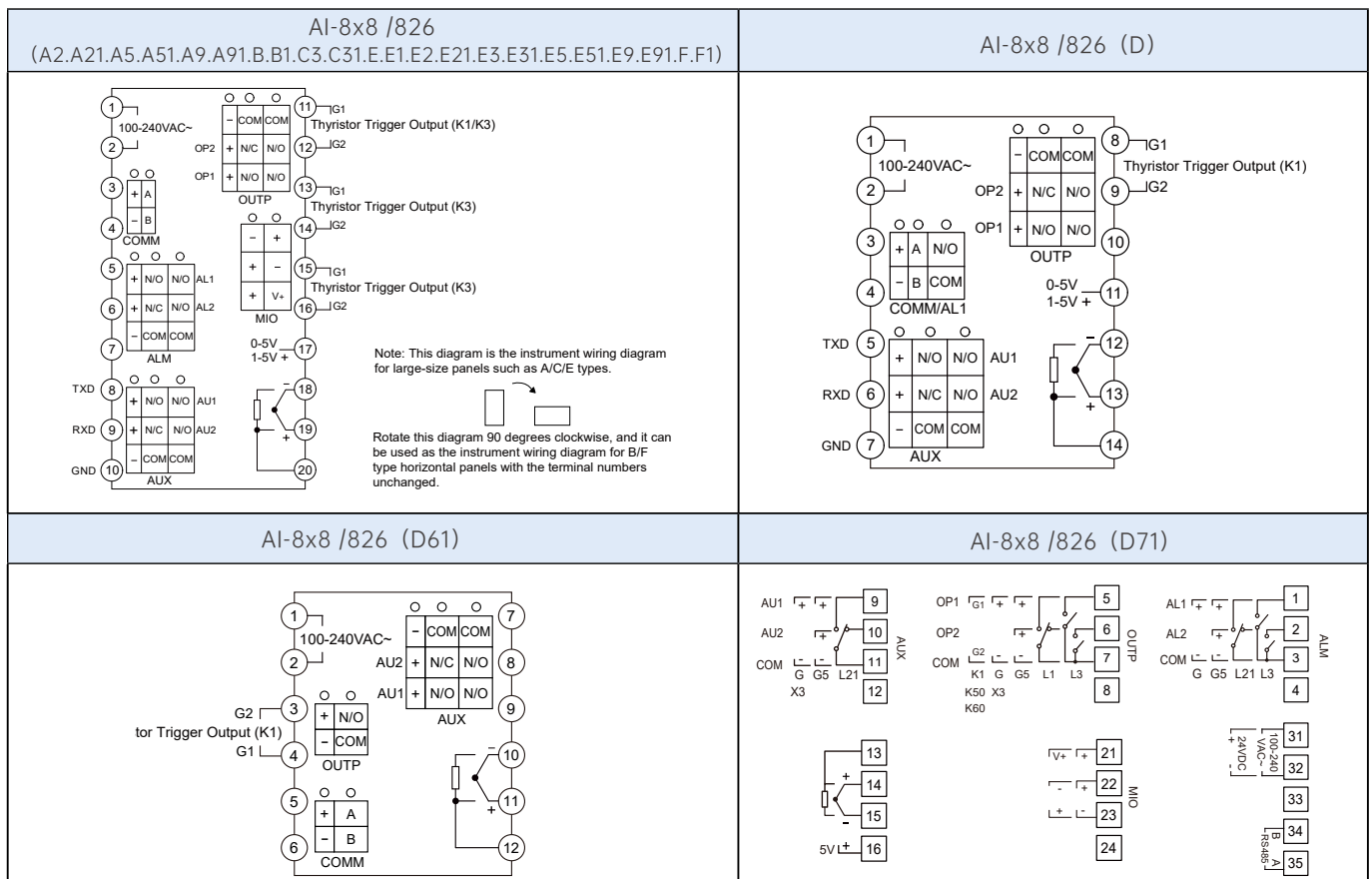

AI-8 series Cascade High Performance Multi-function Temperature Controller / Regulator

AI □ □ □ □ □ □ □ □ □ □										Description	
Model	899										Cascade High-Performance Temperature Controller/Regulator, ± 0.05% /± 0.1% of displayed value., 10-Year Warranty
	889										Cascade High-Performance Temperature Controller/Regulator, ± 0.1% of displayed value., 10-Year Warranty
	869										Cascade High-Performance Temperature Controller/Regulator, ± 0.15% of displayed value., 5-Year Warranty
	859										Cascade High-Performance Temperature Controller/Regulator, ± 0.2% of displayed value., 5-Year Warranty
Panel Dimension (WxH)	A										Panel Dimensions 96×96mm
	B										Panel Dimensions 160×80mm
	C3										Panel Dimensions 80×160mm, Three Rows of 4-Digit Display
	E										Panel Dimensions 48×96mm
	E5										DIN Rail Mounting, Width 45mm, No Built-in Display, External E85 Display Unit
	F										Panel Dimensions 96×48mm
Multi-I/O (MIO)				12/15							Digital Input Module for Et Event Input Configurable functions include: Run Start/ Stop, Setpoint/PID Parameter Switching, Direct/ Reverse Action Switching, Manual/Automatic Control Switching, Run/Stop (12 is single-channel, 15 is dual-channel).
				V*							V24, V12, V10 Modules: 24VDC, 12VDC, 10VDC power supply modules, respectively.
Main Output (OUTP)				L1							Large-Size Single-Channel Relay Output Module, Capacity 250VAC/2A
				L3							Dual-Channel Relay Output Module, Two Sets of Normally Open Contacts, Capacity 250VAC/2A
				G							Solid-State Relay Drive Voltage Output Module (DC12V/30mA)
				W1/W2							Thyristor Non-Contact Switch Output Module (W1: Normally Open, W2: Normally Closed)
				X3/X5							Optically Isolated Linear Current Output Module (X3 uses instrument power supply, X5 has its own isolated power supply)
				K1/K3							Thyristor Zero-Crossing Trigger Output Module (K1: Single-Channel, K3: Three-Channel; K3 occupies the MIO port)
				K50/k60							Thyristor Phase-Angle Trigger Output Module (K50 for 220V, K60 for 380V voltage)

Alarm (ALM)	L21				Compact Single-Channel Relay Output Module, Capacity 250VAC/1A
	L3				Dual-Channel Relay Output Module, Two Sets of Normally Open Contacts, Capacity 250VAC/2A
	G				Solid-State Relay Drive Voltage Output Module (DC12V/30mA)
	W1/W2				Thyristor Non-Contact Switch Output Module (W1: Normally Open, W2: Normally Closed)
Auxiliary (AUX)	L1				Large-Size Single-Channel Relay Output Module, Capacity 250VAC/2A
	L21				Compact Single-Channel Relay Output Module, Capacity 250VAC/1A
	L3				Dual-Channel Relay Output Module, Two Sets of Normally Open Contacts, Capacity 250VAC/2A
	G				Solid-State Relay Drive Voltage Output Module (DC12V/30mA)
	X3/X5				Optically Isolated Linear Current Output Module (X3 uses instrument power supply, X5 has its own isolated power supply)
Communication (COMM)	12 / 15				Digital Input Module for Et Event Input Configurable functions include: Run Start/ Stop, Setpoint/PID Parameter Switching, Direct/ Reverse Action Switching, Manual/Automatic Control Switching, Run/Stop (Single-Channel).
	S/S4				Optically Isolated RS485 Communication Interface (S uses instrument power supply, S4 has its own isolated power supply)
	X3/X5				Optically Isolated Linear Current Output Module (X3 uses instrument power supply, X5 has its own isolated power supply)
Power					Default Power Supply: 100-240VAC
				-24VDC	Power Supply: 24VDC
Input Signal				-IN**	Specified Signal Input: ** is the input type code (refer to the Input Specification Table on page P03).
				-INRT	Various RTD Inputs: Default setting is PT100 input.
				-INTC	Various Thermocouple Inputs: Default setting is K-type input.
				-INAL	Universal Input: Input specification is not preset; customers can customize it.

AI □ □ □ □ □ □ □ □ □ □										Description	
Model	899										Cascade High-Performance Temperature Controller/Regulator, ± 0.05% /± 0.1% of displayed value., 10-Year Warranty
	889										Cascade High-Performance Temperature Controller/Regulator, ± 0.1% of displayed value., 10-Year Warranty
	869										Cascade High-Performance Temperature Controller/Regulator, ± 0.15% of displayed value., 5-Year Warranty
	859										Cascade High-Performance Temperature Controller/Regulator, ± 0.2% of displayed value., 5-Year Warranty
Panel Dimension (WxH)	D71										DIN rail mounting, width 22.5mm, with built-in display, bus-type power supply and communication.
input (M1)		J1									2-Loop Thermocouple Input Module
		J2									2-Loop Thermal Resistance Input Module
Main Output (OUTP)		L1									Large-Size Single-Channel Relay Output Module, Capacity 250VAC/2A
		L3									Dual-Channel Relay Output Module, Two Sets of Normally Open Contacts, Capacity 250VAC/2A
		G									Solid-State Relay Drive Voltage Output Module (DC12V/30mA)
		W1/W2									Thyristor Non-Contact Switch Output Module (W1 is normally open, W2 is normally closed)
		X3									Optically Isolated Linear Current Output Module (X3 uses instrument power supply)
		K1/K3									Thyristor Zero-Crossing Trigger Output Module (K1 is single-channel, K3 is three-channel; K3 occupies the MIO port)
		K50/k60									Thyristor Phase-Angle Trigger Output Module (K50 for 220V, K60 for 380V voltage)
Alarm (ALM)		L21									Compact Single-Channel Relay Output Module, Capacity 250VAC/1A
		L3									Dual-Channel Relay Output Module, Two Sets of Normally Open Contacts, Capacity 250VAC/2A
		G									Solid-State Relay Drive Voltage Output Module (DC12V/30mA)
		W1/W2									Thyristor Non-Contact Switch Output Module (W1: Normally Open, W2: Normally Closed)
Auxiliary (AUX)		L1									Large-Size Single-Channel Relay Output Module, Capacity 250VAC/2A
		L21									Compact Single-Channel Relay Output Module, Capacity 250VAC/1A
		L3									Dual-Channel Relay Output Module, Two Sets of Normally Open Contacts, Capacity 250VAC/2A
		G									Solid-State Relay Drive Voltage Output Module (DC12V/30mA)
		X3									Optically Isolated Linear Current Output Module (X3 uses instrument power supply)
Communication (COMM)							S2				Optically Isolated RS485 Communication Interface Module (occupies the second set of 12V isolated power supply)
Power								-24VDC			Default Power Supply: 24VDC
								-220VAC			Power Supply: 24VDC

Input Signal	-IN**	Specified Signal Input: ** is the input type code (refer to the Input Specification Table on page P03).
	-INRT	Various RTD Inputs: Default setting is PT100 input.
	-INTC	Various Thermocouple Inputs: Default setting is K-type input.
	-INAL	Universal Input: Input specification is not preset; customers can customize it.

Example of Model Selection:

AI-859 D71 J1 G L21 S - 24VDC
 ① ② ③ ④ ⑤ ⑥ ⑦

- ① The main unit model is AI859, a cascade high-performance multifunctional temperature controller/regulator with Class 0.2 accuracy and a 5year warranty.
- ② The unit features a D71 housing, DINrail mounted, with a width of 22.5 mm and a builtin display.
- ③ The input (M1) is J1, providing two thermocouple input channels. The auxiliary input (MIO) is unoccupied.
- ④ The main output (OUTP) uses a solidstate relay driving voltage module, rated at 12 VDC / 30 mA.
- ⑤ The auxiliary output/alarm (AUX) is equipped with the L21 module, providing one alarm output with both normallyopen and normallyclosed contacts.
- ⑥ The communication (COMM) is fitted with a communication module, indicating that the instrument supports RS485 communication.
- ⑦ The instrument is powered by a 24 VDC power supply.

Wire Diagram Diagrama

Note: Due to technical upgrades or special orders, if the wiring diagram included with the instrument differs from this selection manual, please follow the wiring diagram provided with the instrument.

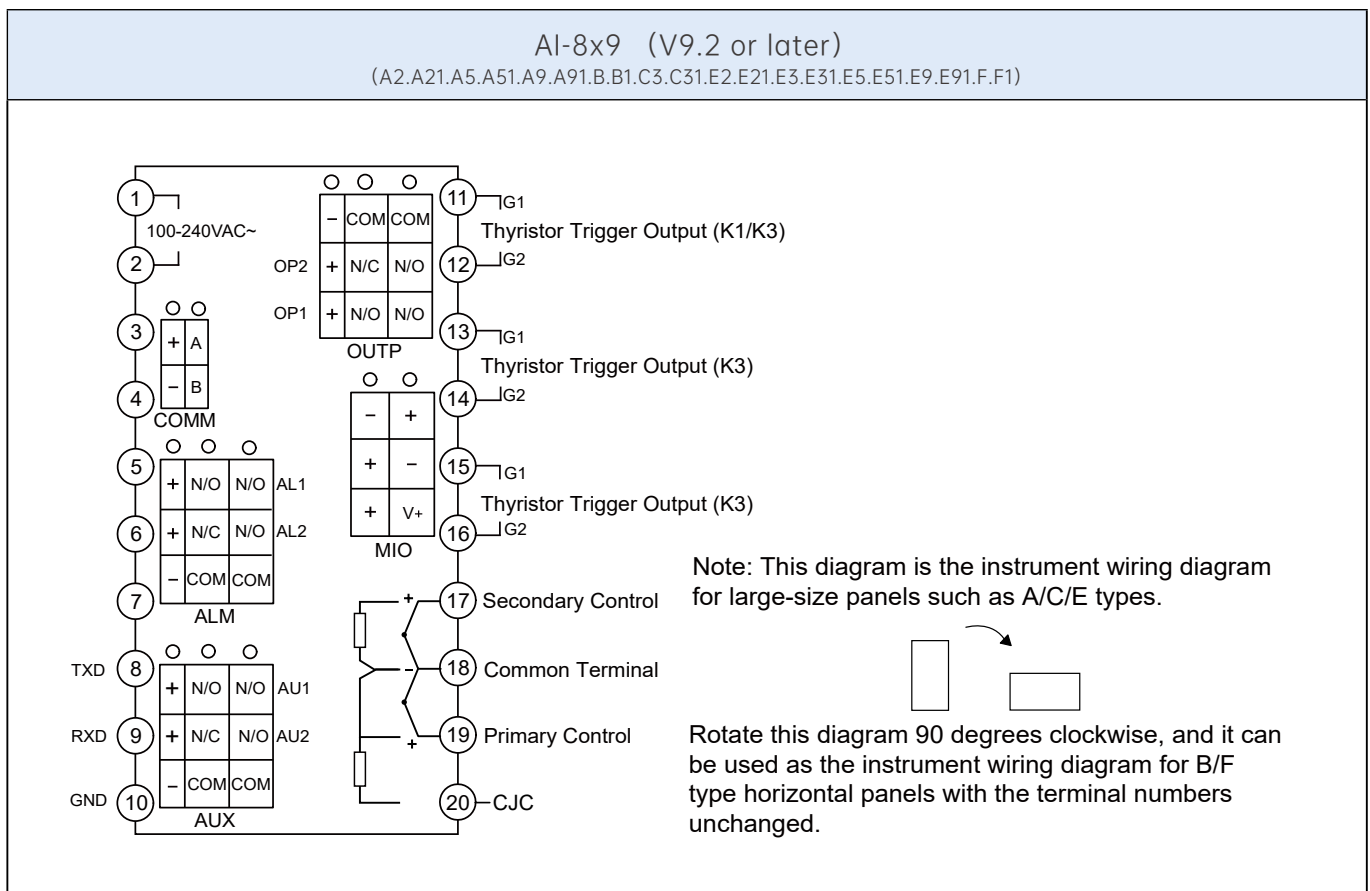

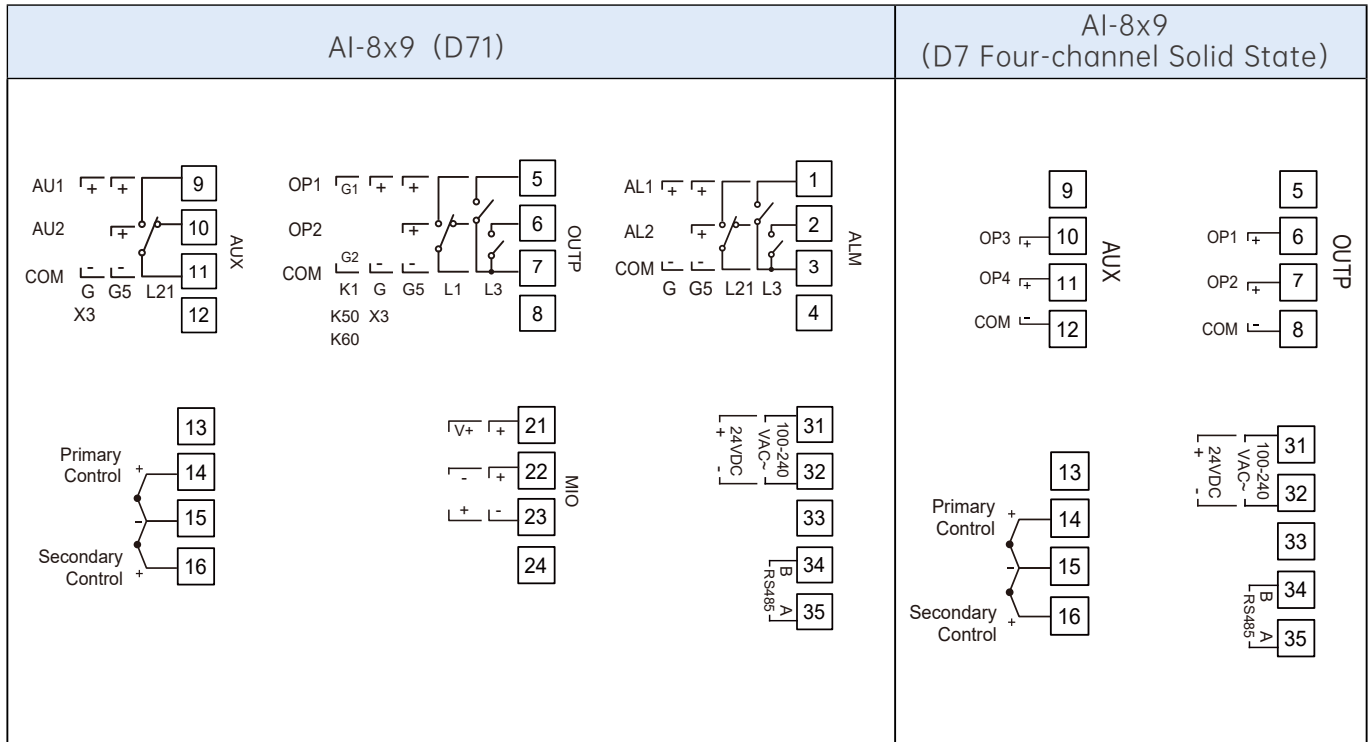

AI-8XXX Multi-loop High-Performance PID Controller

Features

Series Overview:

Yudian AI-8XXX series multi-loop instruments include high-precision multifunctional, multifunctional, general-purpose, and high-temperature resistant series products, suitable for precise control of physical quantities such as temperature, pressure, flow, and liquid level.

The high-precision multifunctional series employs premium components and supports complex control algorithms such as cascade and feedforward, making it ideal for customers with the highest standards for measurement accuracy, sampling rate, functionality, and reliability. It has been successfully applied in critical semiconductor industry equipment with extremely stringent temperature control requirements.

The multifunctional general-purpose series balances rich functionality with cost efficiency and supports advanced algorithms like cascade control. It has been successfully adopted in industries such as photovoltaic core equipment and high-end material processing.

The economy series is designed for cost-sensitive, high-volume applications and has been successfully deployed in industries including leading lithium battery production lines, photovoltaic post-processing equipment, and machinery manufacturing.

Customers are advised to provide technical specifications, functional requirements, application industry, volume, and target price range. Our sales team, in coordination with technical support, will recommend the appropriate model and provide a quotation.

Measurement Accuracy and Minimum Sampling Cycle:

Measurement accuracy and minimum sampling cycle are the most critical hardware specifications of a temperature controller. Measurement accuracy typically ranges from Class 0.1 to Class 0.3, with special customization available up to Class 0.05.

Accuracy class refers to the maximum permissible measurement error for each controller under reference conditions during mass production. For example, Class 0.1 means the maximum error of any individual unit does not exceed 0.1% of the full scale.

Note: In mass production, errors generally follow a distribution curve—a statistical concept. The error observed in a sample unit usually does not represent the maximum error.

Typically, temperature drift for a Class 0.1 instrument does not exceed 50 ppm/°C of the full scale, for Class 0.2 not exceeding 100 ppm/°C, and so on.

High-precision products deliver better consistency and more stable temperature control, enabling energy savings, improved efficiency, and cost reduction. Models with fast sampling cycles are suitable for applications requiring rapid heating or cooling.

Warranty Policy:

1.The free warranty policy covers individual instrument damage caused by customer reasons (excluding large-scale or intentional damage). However, normal wear and tear of components with a limited lifespan—such as burnt relay contacts—is not covered under warranty.

2.Our product quality standards and warranty policy adhere to principles exceeding national and industry standards. If customers have special requirements regarding the warranty period, these can be specified in the purchase contract or supplier agreement.



(1) AI-88X8 Series High-Precision Multi-Function PID Controllers, with optional FA high-reliability grade products suitable for the semiconductor industry.

- Measurement accuracy class 0.1, with each loop independently using a dedicated 24-bit high-performance low-temperature-drift A/D converter. Compared to multi-channel instruments using a single A/D chip, this design significantly improves anti-interference capability and reduces noise, while maintaining high 50Hz interference immunity even under 20ms high-speed sampling conditions.
- Advanced AI self-tuning and self-learning control algorithms enable 4-channel PID or dual-channel cascade PID control, with a minimum control cycle of only 40ms for all 4 channels. It also supports standard cascade control and Yudian's intelligent scaling cascade control technology.
- Equipped with four independent high-precision, low-temperature-drift reference voltage sources. For thermocouple input models, a built-in PT100 platinum resistor provides high-precision cold junction compensation, significantly improving compensation accuracy.
- AI-8848D92J2 is specifically designed for four-wire PT1000 and PT100 high-precision measurement input and control, supporting 0.001degree resolution.
- AI-8848GD91J3/J4 offer 4channel isolated linear voltage and current inputs, respectively.
- AI-8848GD91J7 provides 4channel isolated universal input for thermocouples and RTDs.
- Input linearization correction function, where each channel can be independently calibrated, and different input specifications can be set per channel.
- Programmable input channels, enabling functions such as using a single input as the measured value for multiple control channels.
- Programmable output channels, supporting multi-channel coordinated output, one-input-multiple-output functions, and more.
- Multichannel synchronized heating function that tracks a specified channel's measured value as the setpoint.
- Supports up to 8 NPN or SSR outputs, or linear current/voltage outputs, with up to 96 programmable output channels that can be expanded via external output modules.
- Standalone unit supports MODBUS communication protocol via RS485 interface. Combined configurations also offer optional communication methods such as TCP, EtherCAT, and Devi
- ceNET.

Model Selection & Specifications

AI	<input type="checkbox"/>	<input type="checkbox"/>	<input type="checkbox"/>	<input type="checkbox"/>	<input type="checkbox"/>	<input type="checkbox"/>	Description
Model	8848D92J2						± 0.1% of displayed value./ D92 Size / 4-loop Four-Wire RTD Input Controller
	8848GD91J3						± 0.1% of displayed value./ D91 Size / 4-loop Isolated 0~5V/0~10V Voltage Input Controller
	8848GD91J4						± 0.1% of displayed value./ D91 Size / 4-loop Isolated 4~20mA Current Input Controller
	8848GD91J7						± 0.1% of displayed value / D91 Size / 4-loop Isolated Thermocouple / Three-Wire RTD Universal Input Controller
	8848D92J2FA						Based on 8848D92J2 with built-in semiconductor temperature control algorithm and high-standard quality management components
	8848GD91J3 FA						Based on 8848GD91J3 with built-in semiconductor temperature control algorithm and high-standard quality management components
	8848GD91J4 FA						Based on 8848GD91J4 with built-in semiconductor temperature control algorithm and high-standard quality management components
	8848GD91J7 FA						Based on 8848GD91J7 with built-in semiconductor temperature control algorithm and high-standard quality management components
	8888D92J0						± 0.1% of displayed value / D92 Size / 8-loop Three-Wire RTD Input Controller
	8888GD92J1						± 0.1% of displayed value / D92 Size / 8-loop Isolated Thermocouple Input Controller
	8888GD92J4						± 0.1% of displayed value / D92 Size / 8-loop Isolated 4~20mA Current Input Controller

	8888D92J0 FA					Based on 8888D92J0 with built-in semiconductor temperature control algorithm and high-standard quality management components
	8888GD92J1 FA					Based on 8888D92J1 with built-in semiconductor temperature control algorithm and high-standard quality management components
	8888GD92J4 FA					Based on 8888D92J4 with built-in semiconductor temperature control algorithm and high-standard quality management components
Main Output (OUTP)	G71					4-Channel Isolated NPN Output – Can be externally connected to 5~24VDC to drive SSR or intermediate relays; maximum external voltage 28VDC; each channel maximum drive current 100mA (suitable for control)
	X74					4-Channel Optically Isolated 0~20mA/4~20mA Linear Current Output Module (does not use the instrument's internal isolated power supply); drive voltage approx. 6V; maximum load capacity approx. 260 ohms
	X75					4-Channel Optically Isolated 0~10V/2~10V Linear Voltage Output Module (does not use the instrument's internal isolated power supply)
	X710					4-Channel Optically Isolated 0~20mA/4~20mA Linear Current Output Module (does not use the instrument's internal isolated power supply); drive voltage approx. 12V; maximum load capacity approx. 500 ohms
Main Output 2 (AUX) (Optional for 6-channel/ 8-channel Host Models)	G71					4-Channel Isolated NPN Output – Can be externally connected to 5~24VDC to drive SSR or intermediate relays; maximum external voltage 28VDC; each channel maximum drive current 100mA (suitable for control)
	X74					4-Channel Optically Isolated 0~20mA/4~20mA Linear Current Output Module (does not use the instrument's internal isolated power supply); drive voltage approx. 6V; maximum load capacity approx. 260 ohms
	X75					4-Channel Optically Isolated 0~10V/2~10V Linear Voltage Output Module (does not use the instrument's internal isolated power supply)
	X710					4-Channel Optically Isolated 0~20mA/4~20mA Linear Current Output Module (does not use the instrument's internal isolated power supply); drive voltage approx. 12V; maximum load capacity approx. 500 ohms
Alarm and Communication Expansion (ALM/YULINK)	G61					2-Channel Isolated NPN Output – Can be externally connected to 5~24VDC to drive SSR or intermediate relays; maximum external voltage 28VDC; each channel maximum drive current 100mA (suitable for alarm)
	G62					2-Channel Isolated PNP Output – Can be externally connected to 5~24VDC to drive SSR or intermediate relays; maximum external voltage 28VDC; each channel maximum drive current 100mA (suitable for alarm)
	G53					2-Channel Solid State Relay Alarm Output (self-powered); compatible with PNP/NPN wiring; can be externally connected to 5~24VDC to drive SSR or intermediate relays; maximum external voltage 28VDC; each channel maximum drive current 50mA (suitable for alarm, used with X74)
Communication (COMM)				S2		Integrated 485 Communication Module, supports MODBUS-RTU protocol
Power					-24VDC	Default Power Supply: 24VDC

(2) AI-86X8 Series Multi-Function PID Controller, featuring cascade control algorithms and I/O programming capabilities

- Independent A/D converter per channel, suitable for applications requiring high-speed sampling and high resolution.
- Measurement accuracy of class 0.15, with 4 inputs supporting 2-loop cascade control, making it a mid-to-high end solution for the photovoltaic industry.
- Optional NPN, PNP, or SSR drive outputs, or linear voltage/current outputs; optional 2-channel alarm output. Features advanced AI self-tuning and self-learning control algorithms, including fast self-tuning capability.
- Standalone unit supports MODBUS communication protocol via RS485 interface, with baud rate range from 1,200 ~115,200; combined configurations also offer optional communication methods such as TCP, EtherCAT, and DeviceNET.
- Except for the absence of semiconductor-specific algorithms, other functions are comparable to the AI8848 series.

Model Selection & Specifications

AI	<input type="checkbox"/>	<input type="checkbox"/>	<input type="checkbox"/>	<input type="checkbox"/>	<input type="checkbox"/>	<input type="checkbox"/>	Description
Model	8648GD91J3						± 0.1% of displayed value. / D92 Size / 4-loop Four-Wire RTD Input Controller
	8648GD91J4						± 0.15% of displayed value. / D91 Size / 4-loop Isolated 4~20mA Current Input Controller
	8648GD91J7						± 0.15% of displayed value. / D91 Size / 4-loop Isolated Thermocouple / Three-Wire RTD Universal Input Controller
	8688D92J0						± 0.15% of displayed value. / D92 Size / 8-loop Three-Wire RTD Input Controller
	8688GD92J1						± 0.15% of displayed value. / D92 Size / 8-loop Isolated Thermocouple Input Controller
	AI-8688GD92J4						± 0.15% of displayed value. / D92 Size / 8-loop Isolated 4~20mA Current Input Controller
Main Output (OUTP)		G71					4-Channel Isolated NPN Output – Can be externally connected to 5~24VDC to drive SSR or intermediate relays; maximum external voltage 28VDC; each channel maximum drive current 100mA (suitable for control)
		X74					4-Channel Optically Isolated 0~20mA/4~20mA Linear Current Output Module (does not use the instrument's internal isolated power supply); drive voltage approx. 6V; maximum load capacity approx. 260 ohms
		X75					4-Channel Optically Isolated 0~10V/2~10V Linear Voltage Output Module (does not use the instrument's internal isolated power supply)
		X710					4-Channel Optically Isolated 0~20mA/4~20mA Linear Current Output Module (does not use the instrument's internal isolated power supply); drive voltage approx. 12V; maximum load capacity approx. 500 ohms
Main Output 2 (AUX) (Optional for 6-channel/ 8-channel Host Models)		G71					4-Channel Isolated NPN Output – Can be externally connected to 5~24VDC to drive SSR or intermediate relays; maximum external voltage 28VDC; each channel maximum drive current 100mA (suitable for control)
		X74					4-Channel Optically Isolated 0~20mA/4~20mA Linear Current Output Module (does not use the instrument's internal isolated power supply); drive voltage approx. 6V; maximum load capacity approx. 260 ohms
		X75					4-Channel Optically Isolated 0~10V/2~10V Linear Voltage Output Module (does not use the instrument's internal isolated power supply)
		X710					4-Channel Optically Isolated 0~20mA/4~20mA Linear Current Output Module (does not use the instrument's internal isolated power supply); drive voltage approx. 12V; maximum load capacity approx. 500 ohms

Alarm and Communication Expansion (ALM/YULINK)	G61			2-Channel Isolated NPN Output – Can be externally connected to 5~24VDC to drive SSR or intermediate relays; maximum external voltage 28VDC; each channel maximum drive current 100mA (suitable for alarm)
	G62			2-Channel Isolated PNP Output – Can be externally connected to 5~24VDC to drive SSR or intermediate relays; maximum external voltage 28VDC; each channel maximum drive current 100mA (suitable for alarm)
	G53			2-Channel Solid State Relay Alarm Output (self-powered); compatible with PNP/NPN wiring; can be externally connected to 5~24VDC to drive SSR or intermediate relays; maximum external voltage 28VDC; each channel maximum drive current 50mA (suitable for alarm, used with X74)
Communication (COMM)		S2		Integrated 485 Communication Module, supports MODBUS-RTU protocol
Power			-24VDC	Default Power Supply: 24VDC

(3) AI-8XXX Series Universal PID Controller for multi-loop and low-cost requirements

- Class 0.2 measurement accuracy, a multiloop intelligent temperature controller.
- Uses a 24bit A/D converter in scanmode measurement, offering high costperformance. Can also serve as an 8loop measurement/data acquisition unit when no output modules are installed.
- Optional NPN, PNP, or SSR drive outputs, or linear voltage/current outputs; optional 2loop alarm output.
- Features advanced AI selftuning and selflearning control algorithms, including fast selftuning capability.
- Standalone unit supports the MODBUS communication protocol via an RS485 interface, with a baud rate range of 1,200 ~ 115,200. Combined configurations also offer optional communication methods such as TCP, EtherCAT, and DeviceNET.

Model Selection & Specifications

AI	<input type="checkbox"/>	<input type="checkbox"/>	<input type="checkbox"/>	<input type="checkbox"/>	<input type="checkbox"/>	<input type="checkbox"/>	Description
Model	AI-8588D92J0						Class 0.2 Accuracy / D92 Size / 8loop ThreeWire PT100 and PT1000 Compatible Input, 400 ms Sampling Rate
	AI-8588GD92J1						Class 0.2 Accuracy / D92 Size / 8loop Isolated Thermocouple Input Controller
	AI-8548GD91J7						Class 0.2 Accuracy / D91 Size / 4loop Isolated Thermocouple / 3Wire RTD Universal Input Controller
	AI-8566GD91J1						Class 0.2 Accuracy / D91 Size / 6loop Isolated Thermocouple Input Controller
	AI-8546D91J0						Class 0.2 Accuracy / D91 Size / 4loop ThreeWire RTD Input Controller
	AI-8546GD91J1						Class 0.2 Accuracy / D91 Size / 4loop Isolated Thermocouple Input Controller
Main Output (OUTP)		G71					4-Channel Isolated NPN Output – Can be externally connected to 5~24VDC to drive SSR or intermediate relays; maximum external voltage 28VDC; each channel maximum drive current 100mA (suitable for control)
		X74					4-Channel Optically Isolated 0~20mA/4~20mA Linear Current Output Module (does not use the instrument's internal isolated power supply); drive voltage approx. 6V; maximum load capacity approx. 260 ohms
		X75					4-Channel Optically Isolated 0~10V/2~10V Linear Voltage Output Module (does not use the instrument's internal isolated power supply)
		X710					4-Channel Optically Isolated 0~20mA/4~20mA Linear Current Output Module (does not use the instrument's internal isolated power supply); drive voltage approx. 12V; maximum load capacity approx. 500 ohms

Main Output 2 (AUX) (Optional for 6-channel/ 8-channel Host Models)	G71			4-Channel Isolated NPN Output – Can be externally connected to 5~24VDC to drive SSR or intermediate relays; maximum external voltage 28VDC; each channel maximum drive current 100mA (suitable for control)
	X74			4-Channel Optically Isolated 0~20mA/4~20mA Linear Current Output Module (does not use the instrument's internal isolated power supply); drive voltage approx. 6V; maximum load capacity approx. 260 ohms
	X75			4-Channel Optically Isolated 0~10V/2~10V Linear Voltage Output Module (does not use the instrument's internal isolated power supply)
	X710			4-Channel Optically Isolated 0~20mA/4~20mA Linear Current Output Module (does not use the instrument's internal isolated power supply); drive voltage approx. 12V; maximum load capacity approx. 500 ohms
Alarm and Communication Expansion (ALM/YULINK)	G61			2-Channel Isolated NPN Output – Can be externally connected to 5~24VDC to drive SSR or intermediate relays; maximum external voltage 28VDC; each channel maximum drive current 100mA (suitable for alarm)
	G62			2-Channel Isolated PNP Output – Can be externally connected to 5~24VDC to drive SSR or intermediate relays; maximum external voltage 28VDC; each channel maximum drive current 100mA (suitable for alarm)
	G53			2-Channel Solid State Relay Alarm Output (self-powered); compatible with PNP/NPN wiring; can be externally connected to 5~24VDC to drive SSR or intermediate relays; maximum external voltage 28VDC; each channel maximum drive current 50mA (suitable for alarm, used with X74)
Communication (COMM)		S2		Integrated 485 Communication Module, supports MODBUS-RTU protocol
Power			-24VDC	Default Power Supply: 24VDC

Converter

AI-EtherCAT	AI-EtherCAT8	Support
	AI-EtherCAT16	Support
	AI-EtherCAT32	Support
AI-ModbusTCP	AI-ModbusTCP1	NOT Support
	AI-ModbusTCP2	NOT Support
	AI-RTU-ModbusTCP1	Support
	AI-RTU-ModbusTCP2	Support

Wire Diagram

Note: Due to technical upgrades or special orders, if the wiring diagram included with the instrument differs from this selection manual, please follow the wiring diagram provided with the instrument.

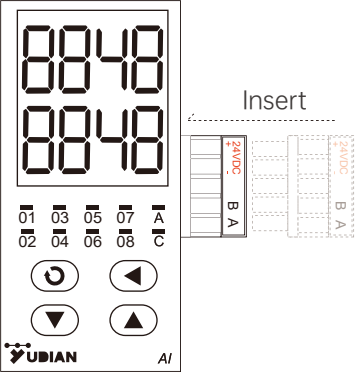
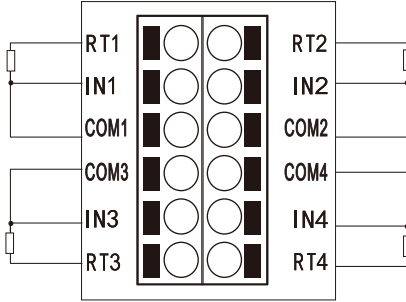
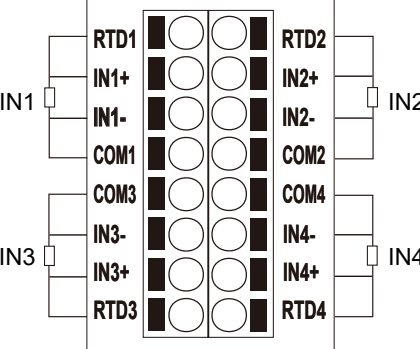
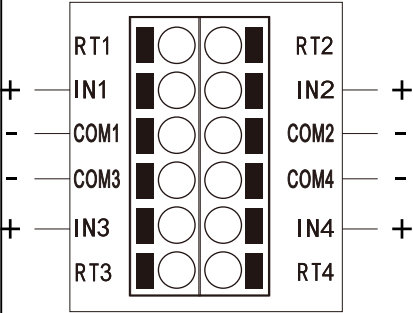
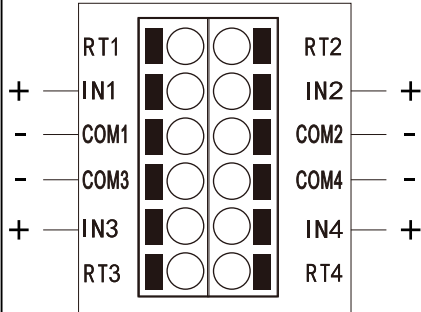
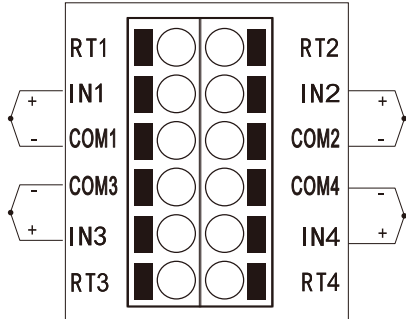
Power and Communication Terminals	4-loop J0 Pt100/Pt1000 RTD Input	4-loop J2 FourWire RTD
		
<p>24V+ and 24V- connect to the switching power supply; A and B connect to the A/B terminals of the host computer. After the DIN rail terminals are snapped together, the power and communication circuits are already connected in parallel.</p> <p>Note: The power and communication terminals are located at the bottom right of the module. When multiple modules are snapped together, only one set of power and communication terminals is required.</p>	<p>Taking the first input loop as an example: when connecting a resistance temperature detector (RTD), connect the two wires of the same color or with lower resistance to IN1 and COM1, and connect the remaining wire to RT1.</p> <p>Note: For PT100 input, wiring must be completed before reapplying power.</p>	<p>Taking the first input loop as an example: a fourwire RTD typically has two pairs of wires with the same color or lower resistance. Connect one pair to IN1+ and RTD1, and the other pair to IN1- and COM1.</p>
4-loop J3 Linear Voltage Input	4-loop J4 Linear Current Input	J7 Thermocouple Input
		
<p>Taking the first input loop as an example, when connecting a linear voltage input, IN1 is positive and COM1 is negative.</p>	<p>Taking the first input loop as an example, when connecting a linear current input, IN1 is positive and COM1 is negative.</p>	<p>Taking the first input loop as an example, when connecting a thermocouple, IN1 is positive and COM1 is negative.</p>

J7 Pt100 RTD Input	6-loop J1 Thermocouple Input	8-loop J0 Pt100/Pt1000 RTD Input
<p>Taking the first input loop as an example: when connecting a resistance temperature detector (RTD), connect the two wires of the same color or with lower resistance to IN1 and COM1, and connect the remaining wire to RT1. Note: For Pt100 input, wiring must be completed before reapplying power.</p>	<p>The wiring for the 6loop thermocouple input connects to INX+ and INX- respectively. Taking the first loop as an example, connect IN1+ to the positive terminal of the thermocouple and IN1- to the negative terminal of the thermocouple.</p>	<p>Taking the first input loop as an example: when connecting an RTD, connect the two wires with the same color or lower resistance to IN1 and COM1, and connect the remaining wire to RT1. Note: For PT100 input, the wiring must be completed before reapplying power.</p>
8-loop J1 Thermocouple Input	8-loop J4 Linear Current Input	
<p>For 8-loop thermocouple input wiring, connect each loop to INX+ and INX- respectively. Taking the first loop as an example, connect IN1+ to the positive terminal of the thermocouple and IN1- to the negative terminal of the thermocouple.</p>	<p>Taking the first input loop as an example, when connecting a linear current input, IN1+ is positive and IN1- is negative.</p>	

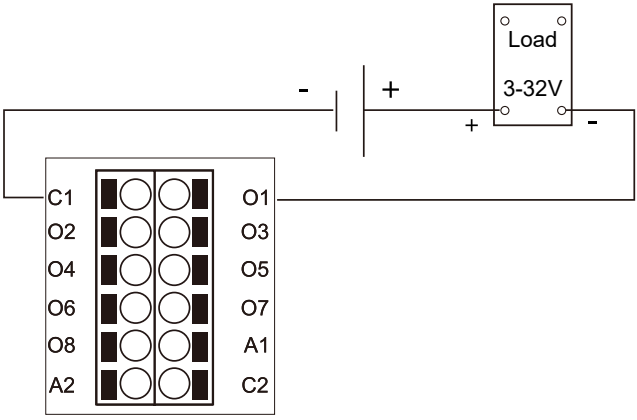
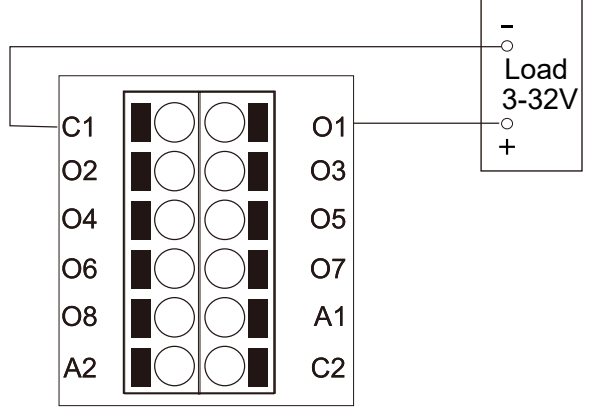
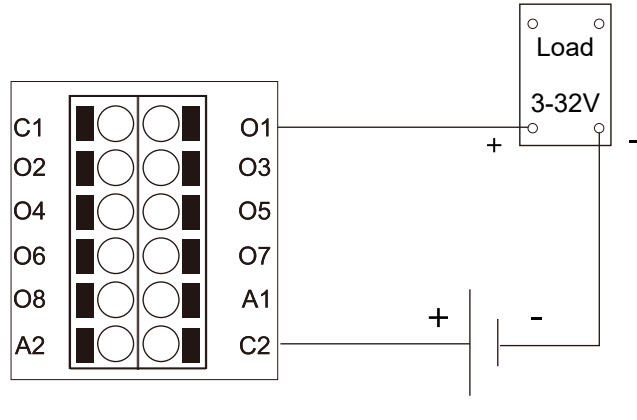
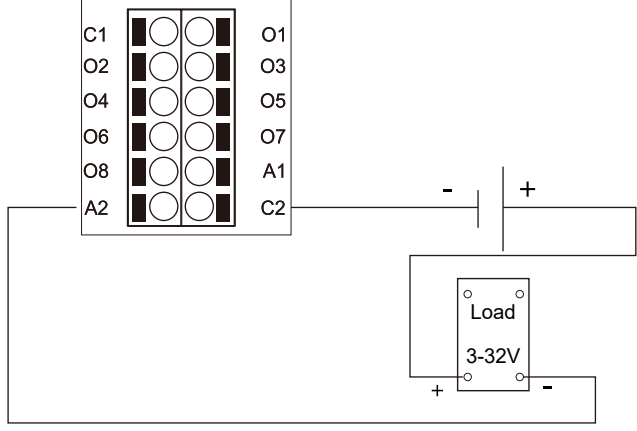
NPN Output	Active Output
	
<p>When installing the NPN output module G71/G61, the common terminal C1 should be connected to the negative terminal of the 24V switching power supply. Terminals O1~O4 should be connected to the negative terminals of the downstream solid-state relays (or other devices), while the positive terminals of the solid-state relays (or other devices) should be connected to the positive terminal of the 24V switching power supply.</p>	<p>When installing an active output module (e.g., X74), connect the common terminal C1 to the negative terminal of the solidstate relay (or other device). Connect terminals O1~O4 to the positive terminals of the downstream solidstate relays (or other devices).</p>
PNP Output	NPN Alarm Output
	
<p>For PNP output, the G72 module paired with the G62 module must be selected. The common terminal C2 should be connected to the positive terminal of the 24V switching power supply. Terminals O1~O4 should be connected to the positive terminals of the downstream solidstate relays (or other devices), and the negative terminals of the solidstate relays (or other devices) should be connected to the negative terminal of the 24V switching power supply.</p> <p>Note: The C1 terminal cannot be used as the common terminal.</p>	<p>When installing an NPN output module such as G61, the common terminal C2 should be connected to the negative terminal of the 24V switching power supply. Terminals A1 and A2 should be connected to the negative terminals of the downstream solidstate relays (or other devices), while the positive terminals of the solidstate relays (or other devices) should be connected to the positive terminal of the 24V switching power supply.</p>

AI-7 Series MultiLoop CostEffective Measurement and Control Instruments

AI <input type="checkbox"/> <input type="checkbox"/> <input type="checkbox"/> <input type="checkbox"/> <input type="checkbox"/> <input type="checkbox"/> <input type="checkbox"/> <input type="checkbox"/>								Description
Model	7668							6L-loop Intelligent Measurement and Control Instrument, Class 0.15 accuracy, 8year free warranty
	7568							6-Loop Intelligent Measurement and Control Instrument, Class 0.2 accuracy, 5year free warranty
	7368							6-Loop Intelligent Measurement and Control Instrument, Class 0.25 accuracy, 3year free warranty
	7268							6-Loop Intelligent Measurement and Control Instrument, Class 0.3 accuracy, 2year free warranty
	7648							4-Loop Intelligent Measurement and Control Instrument, Class 0.15 accuracy, 8year free warranty
	7548							4-Loop Intelligent Measurement and Control Instrument, Class 0.2 accuracy, 5year free warranty
	7348							4-Loop Intelligent Measurement and Control Instrument, Class 0.25 accuracy, 3year free warranty
	7248							4-Loop Intelligent Measurement and Control Instrument, Class 0.3 accuracy, 2year free warranty
Panel Dimension (WxH)	D71							DIN rail mounting, with buttons and dual 4 digit display, power and communication via bus terminals, width 22.5 mm
	D72							Railmount, single row 2digit LED display panel, showing instrument communication address.
Analog Input Signal	J7							Nonisolated thermocouple, two wire RTD, 2N+1 wire RTD, three wire RTD (up to 4 loops) switchable
Main Output (OUTP)	G5							Dualloop isolated solidstate relay driving voltage output (12 V/30 mA)
	G51							Dualloop isolated NPN transistor output, can be externally connected to 524 VDC to drive solid state relays or intermediate relays, each loop drive current 100 mA
	G6							3-loop isolated solid state relay driving voltage output (12 V/30 mA) (not supported on 7x48)
	X6							Dualloop highprecision linear current output, maximum output voltage > 10.5 V (not supported on 7x68)
Main Output 2 (OUTP)	G5							Dualloop isolated solidstate relay driving voltage output (12 V/30 mA)
	G51							Dualloop isolated NPN transistor output, can be externally connected to 524 VDC to drive solidstate relays or intermediate relays, each loop drive current 100 mA
	G6							3-loop isolated solidstate relay driving voltage output (12 V/30 mA) (not supported on 7x48)
	X6							Dualloop high precision linear current output, maximum output voltage > 10.5 V (not supported on 7x68)
Alarm (ALM)	L21							Compact singleloop relay output module, capacity 250 VAC/1 A
	L3							Dual normallyopen relay contact output (2 A/250 VAC)
Communication (COMM)	S							Optically isolated RS485 communication interface (S uses instrument power supply)
	S2							Optically isolated RS485 communication interface (applicable when output is X6)
Power	-24VDC							Default power supply: 24 VDC
	-220VAC							Custom power supply: 100240 VAC

Example of Model Selection:

AI-7568 D71 J7 G6 G6 L21 S2 -24VDC
 ① ② ③ ④ ⑤ ⑥ ⑦ ⑧

- ① The main unit model is AI7568, a sixloop intelligent temperature controller with Class 0.2 accuracy and a 5year warranty.
- ② The unit features a D71 housing, DINrail mounted, with buttons and dual 4digit display, power and communication via bus terminals, width 22.5 mm.
- ③ The input signal supports switchable nonisolated thermocouple, twowire RTD, 2N+1 wire RTD, and threewire RTD (up to 4 loops).
- ④ The main output (OUTP) is equipped with a threeloop isolated solidstate relay driving voltage module, rated at 12 VDC/30 mA.
- ⑤ The main output 2 (OUTP) is equipped with a threeloop isolated solidstate relay driving voltage module, rated at 12 VDC/30 mA.
- ⑥ The alarm port (ALM) is equipped with the L21 module, providing one alarm output with both normallyopen and normallyclosed contacts.
- ⑦ The communication port (COMM) is fitted with a communication module, indicating that the instrument supports RS485 communication.
- ⑧ The instrument is powered by a 24 VDC power supply.

Outline Dimension Drawing

Please refer to Page 05 for the outline dimension drawing.

Wire Diagram

Note: Due to technical upgrades or special orders, if the wiring diagram included with the instrument differs from this selection manual, please follow the wiring diagram provided with the instrument.

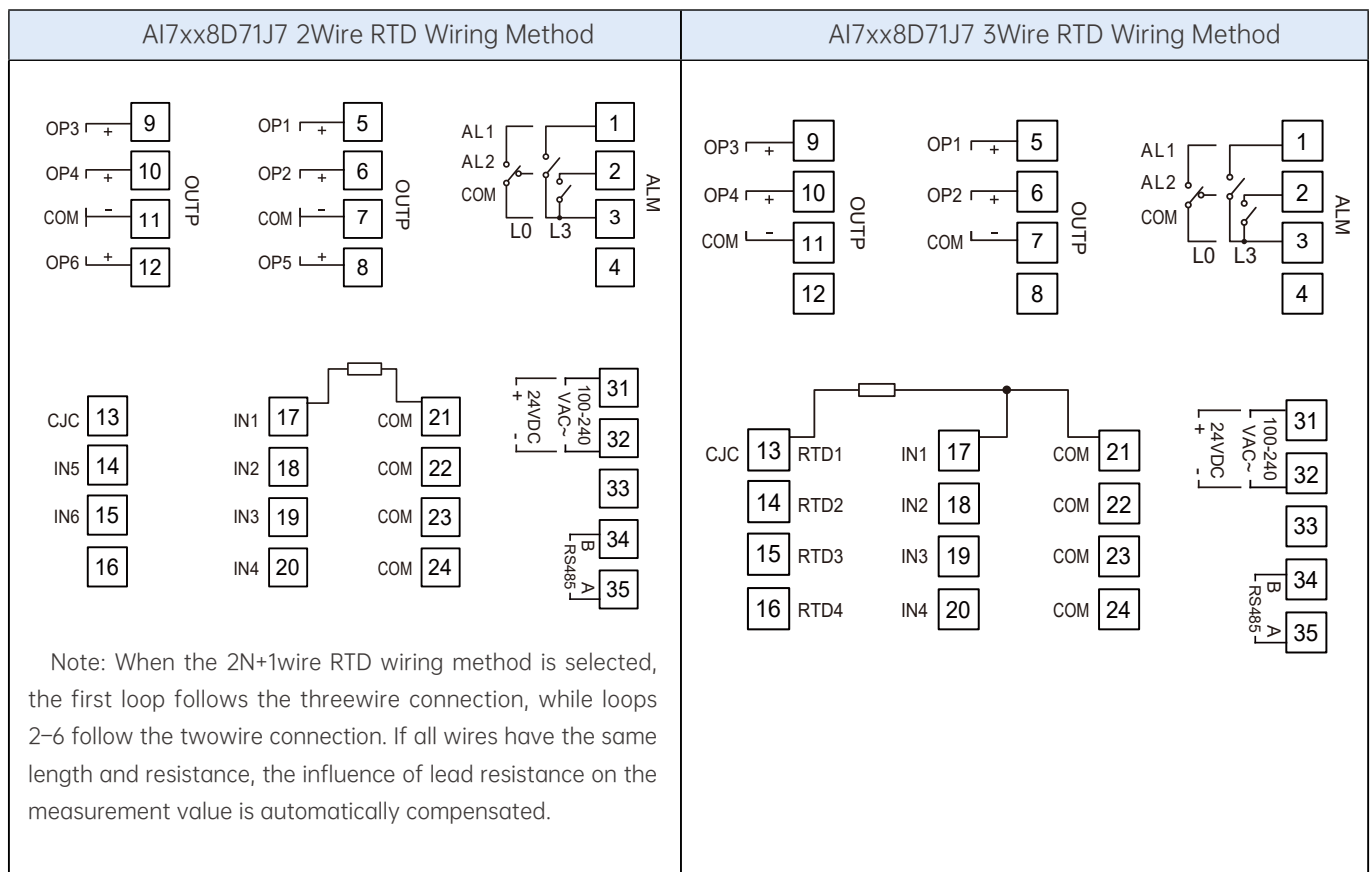

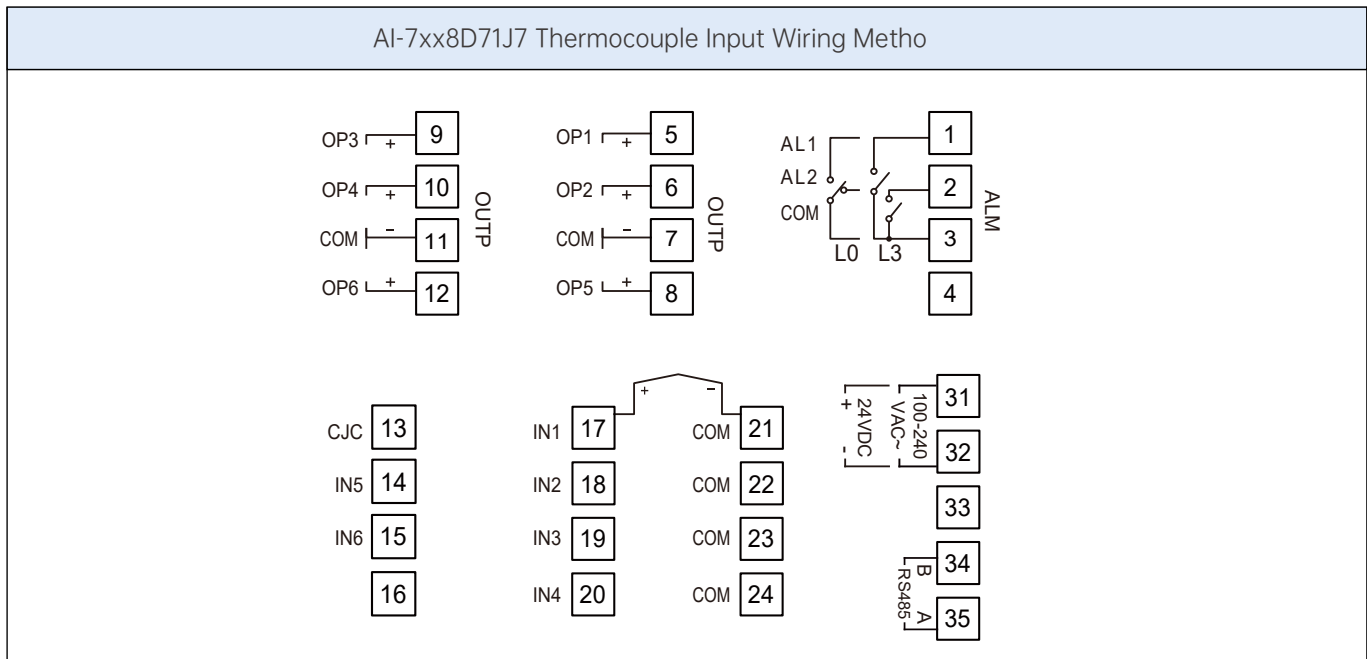

AI-7 Series Multi-Loop Measurement and Alarm Instruments

AI <input type="checkbox"/> <input type="checkbox"/> <input type="checkbox"/> <input type="checkbox"/> <input type="checkbox"/> <input type="checkbox"/> <input type="checkbox"/> <input type="checkbox"/>								Description
Model	702M							2Channel Measurement and Alarm Instrument – with alarm, transmission, communication, and other functions; Class 0.2 measurement accuracy; 5year free warranty
	704M							4Channel Measurement and Alarm Instrument – with alarm, transmission, communication, and other functions; Class 0.2 measurement accuracy; 5year free warranty
	706M							6Channel Measurement and Alarm Instrument – with alarm, transmission, communication, and other functions; Class 0.2 measurement accuracy; 5year free warranty
	732M							2Channel Measurement and Alarm Instrument – with alarm, transmission, communication, and other functions; Class 0.25 measurement accuracy; 3year free warranty
	734M							4Channel Measurement and Alarm Instrument – with alarm, transmission, communication, and other functions; Class 0.25 measurement accuracy; 3year free warranty
	736M							6Channel Measurement and Alarm Instrument – with alarm, transmission, communication, and other functions; Class 0.25 measurement accuracy; 3year free warranty
Panel Dimension (WxH)	A							Panel Dimensions 96×96 mm
	B							Panel Dimensions 160×80 mm (W×H)
	C							Panel Dimensions 80×160 mm (W×H)
	E							Panel Dimensions 48×96 mm (W×H)
	E5							DIN Rail Mounting, Width 45 mm, No Builtin Display, External E85 Display Unit
	F							Panel Dimensions 96×48 mm (W×H)

Input Channel 1 (M1)	J0						1Channel ThreeWire RTD Input Module (or 1channel thermocouple + 1channel twowire RTD input)
	J1						2Channel Thermocouple Input Module, also supports 2channel mV voltage input
	J2						2Channel TwoWire RTD Input Module
	J3						2Channel Voltage Input Module, supports input ranges such as 0-3 V, 0-5 V, 1-5 V, etc
	J31						2Channel 0-10 V Voltage Input Module
	J4						2Channel Current Input Module, supports input ranges such as 0-10 mA, 4-20 mA, 0-20 mA, etc.
	J51						2Channel TwoWire Transmitter Input Module, with builtin 24 V loop power supply
Input Channel 2(M2)	J0-J51						J0-J51 Module functions and selection are the same as "Input Channel 1"
Input Channel 3 (M3) 或 Main Output (OUTP)	J0-J51						J0-J51 Module functions and selection are the same as "Input Channel 1"
	L21						Compact SingleChannel Relay Output Module, capacity 250 VAC/1 A
	L3						DualChannel Relay Output Module, two sets of normallyopen contacts, capacity 250 VAC/2 A
	G						SolidState Relay Drive Voltage Output Module (DC12 V/30 mA)
	X3/X5						Optically Isolated Linear Current Output Module (X3 uses instrument power supply, X5 has its own isolated power supply)
Alarm (ALM)		L21 / L3					L21 / L3 Module functions are the same as described under "Input Channel 3 or Main Output"
Auxiliary (AUX)			L21 / L3				L21 / L3 Module functions are the same as described under "Input Channel 3 or Main Output"
Communication (COMM)				S			Optically Isolated RS485 Communication Interface – uses instrument power supply
				S4			Optically Isolated RS485 Communication Interface – does not use instrument power supply
				X3/X5			Optically Isolated Linear Current Output Module (X3 uses instrument power supply, X5 has its own isolated power supply)
Power							Default Power Supply: 100240 VAC
					-24VDC		Power Supply: 24 VDC

AI □ □ □ □ □ □ □ □										Description
Model	702M									2Channel Measurement and Alarm Instrument – with alarm, transmission, communication, and other functions; Class 0.2 measurement accuracy; 5year free warranty
	704M									4Channel Measurement and Alarm Instrument – with alarm, transmission, communication, and other functions; Class 0.2 measurement accuracy; 5year free warranty
	706M									6Channel Measurement and Alarm Instrument – with alarm, transmission, communication, and other functions; Class 0.2 measurement accuracy; 5year free warranty
	732M									2Channel Measurement and Alarm Instrument – with alarm, transmission, communication, and other functions; Class 0.25 measurement accuracy; 3year free warranty
	734M									4Channel Measurement and Alarm Instrument – with alarm, transmission, communication, and other functions; Class 0.25 measurement accuracy; 3year free warranty
	736M									
Panel Dimension (WxH)	D71									DIN rail mounting, width 22.5 mm, with builtin display, power and communication via bustype terminals.
Multi-I/O (MIO)	J1									2channel thermocouple input module, also supports 2channel mV voltage input.
	J2									2channel 2wire RTD input module.
	J7									Nonisolated thermocouple, twowire RTD, 2N+1 wire RTD, and threewire RTD (up to 4 channels) switchable (exclusive to D71).
Input Channel 2(M2)	J1/J2/J7									The functions and selection of the J1/J2/J7 modules are the same as those described for "Input Channel 1".
Input Channel 3 (M3) 或 Main Output (OUTP)	J1/J2/J7									The functions and selection of the J1/J2/J7 modules are the same as those described for "Input Channel 1".
	L21									Compact single-channel relay output module, capacity 250VAC/1A
	L3									Dual-channel relay output module, two sets of normally open contacts, capacity 250VAC/2A
	G									Solid-state relay driving voltage output module (DC12V/30mA)
	X3									Optically isolated linear current output module (X3 uses instrument power supply)
Alarm (ALM)		L21/L3								The functions of the L21 and L3 modules are the same as those described under "Input Channel 3 or Main Output".
Auxiliary (AUX)			L21/L3							The functions of the L21 and L3 modules are the same as those described under "Input Channel 3 or Main Output".
Communication (COMM)	S									Optically isolated RS485 communication interface – uses instrument power supply.
	S2									Optically isolated RS485 communication interface – applicable to D7 series instruments.
	X3									Optically isolated linear current output module – X3 uses instrument power supply.
Power								-24VDC		Default power supply: 24VDC
								-220VAC		Customized power supply: 100-240VAC

Example of Model Selection:

AI-706M A J1 J1 J1 L3 L3 S
 ① ② ③ ④ ⑤

- ① The main unit model is AI706M, capable of measuring 16 channels of signals, featuring multirange input, cyclic display, alarm, communication, and transmission functions.
- ② The panel size is 96×96 mm.
- ③ The J1 module is installed in positions M1, M2, and M3, indicating that the instrument inputs are 6 channel thermocouples.
- ④ The L3 module is installed in the ALM and AUX ports, providing the instrument with 4 alarm outputs.
- ⑤ The instrument supports RS485 communication.

Wire Diagram

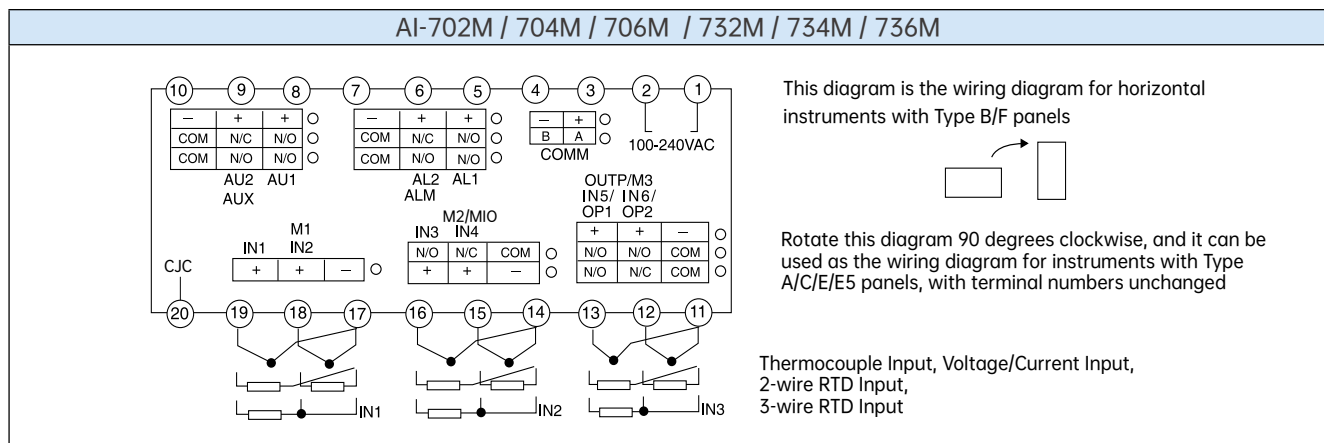

AI Series MultiChannel PID Temperature Controller

AI- □ □ □ □ □ □ □ □ □ □										Description
Model	7028									Class 0.2 Measurement Accuracy, Dual-Channel PID Temperature Controller, 5-year free warranty
	7048									Class 0.2 Measurement Accuracy, Four-Channel PID Temperature Controller, 5-year free warranty
Panel Dimension (W×H)	A									Panel dimensions: 96×96 mm
	B									Panel dimensions: 160×80 mm (W × H)
	C									Panel dimensions: 80×160 mm (W × H)
	D7									DIN Rail Mounting, width 22.5 mm, with built-in display, bus-type power and communication
	E									Panel dimensions: 48×96 mm (W × H)
	E5									DIN Rail Mounting, width 45 mm, no built-in display, external E8 display unit
Input 1, 2 (IN1, IN2)	J1									2-Channel Thermocouple Input Module (also supports 2-channel mV voltage input)
	J2									2-Channel Two-Wire RTD Input Module
	J3									2-Channel Voltage Input Module (supports 0-3 V, 0-5 V, 1-5 V, etc.)
	J4									2-Channel Current Input Module (supports 0-10 mA, 4-20 mA, 0-20 mA, etc.)
	J5									2-Channel Two-Wire Transmitter Input Module (with built-in 24 V loop power supply)

Input 3, 4 (IN3, IN4)	J1					2-Channel Thermocouple Input Module (also supports 2-channel mV voltage input)
	J2					2-Channel Two-Wire RTD Input Module
	J3					2-Channel Voltage Input Module (supports 0-3 V, 0-5 V, 1-5 V, etc.)
	J4					2-Channel Current Input Module (supports 0-10 mA, 4-20 mA, 0-20 mA, etc.)
	J5					2-Channel Two-Wire Transmitter Input Module (with built-in 24 V loop power supply)
Output 1, 2 (OP1, OP2)	G5					Dual-Channel Solid-State Relay Drive Voltage Output Module
Output 3, 4 (OP3, OP4)	G5					Dual-Channel Solid-State Relay Drive Voltage Output Module
Alarm (ALM)	L21					Compact Single-Channel Relay Output Module, capacity 250VAC/1A
	L3					Dual-Channel Relay Output Module, two sets of normally-open contacts, capacity 250VAC/2A
Communication (COMM)	S					Optically Isolated RS485 Communication Interface, uses instrument power supply.
	S2					Optically Isolated RS485 Communication Interface (applicable to D7 series instruments).
	S4					Optically Isolated RS485 Communication Interface, does not use instrument power supply.
Power	Q					Elegant Black
	Z					Classic Light Color

Example of Model Selection :

AI-7048AJ2J2G5G5L3S

AI-7028E5J1G5L0S

Wire Diagram

Note: Due to technical upgrades or special orders, if the wiring diagram included with the instrument differs from this selection manual, please follow the wiring diagram provided with the instrument.

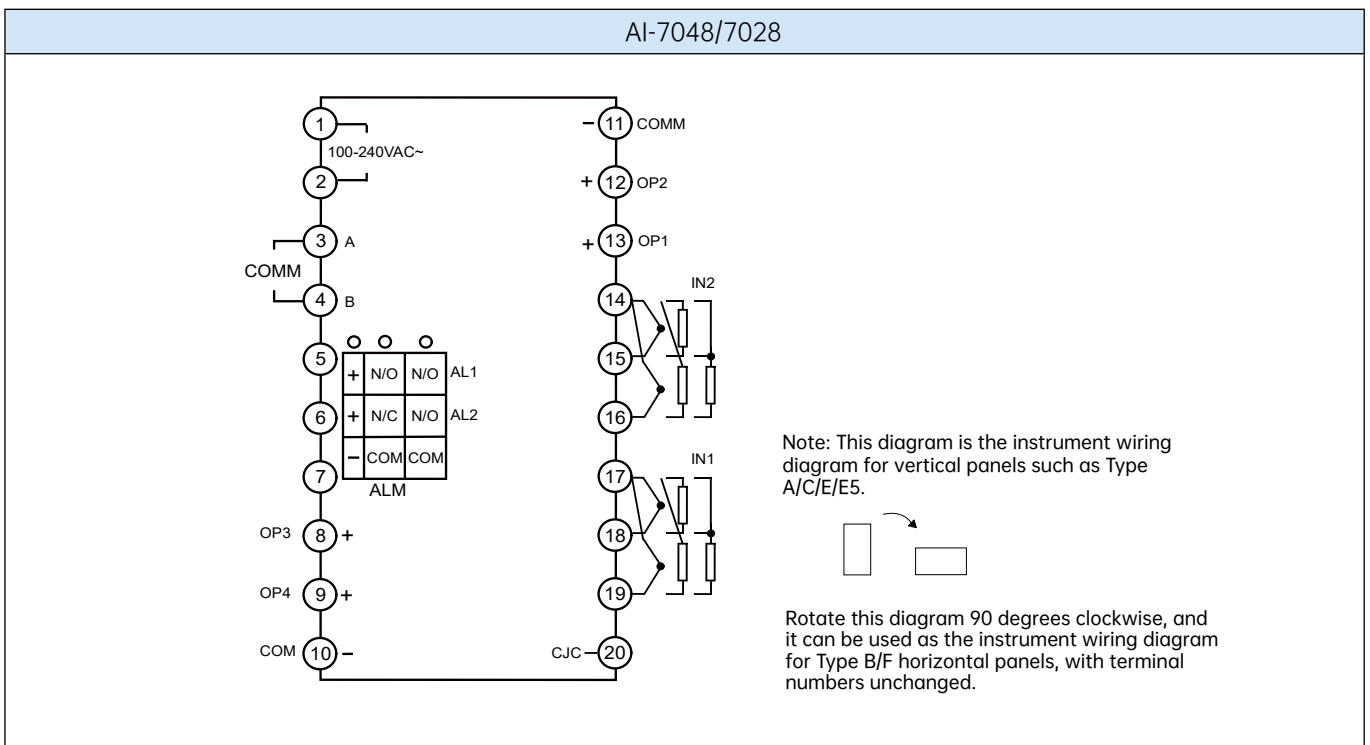

AI-208/218 Economy Intelligent Temperature Controller

AI- □ □ □ □ □ □ □ □								Description
Model	208							Economy AI Temperature Controller, Class 0.3 accuracy, dual 4digit display, 2 year free warranty.
	218							Economy AI Temperature Controller, supports multiple output functions, Class 0.3 accuracy, dual 4digit display.
Panel Dimension (WxH)	A1							Panel Dimensions 96×96mm
	D							Panel Dimensions 72×72mm
	D21							Panel Dimensions 48×48mm (10 wiring terminals)
	E1							Panel Dimensions 48×96mm
	F1							Panel Dimensions 96×48mm
Main Output (OUTP)	G1							Nonisolated energysaving SSR drive voltage output (5V/30mA)
	L1							Relay contact switch output (250V/2A)
	X3/X5							Optically isolated linear current output module (X3 uses instrument power supply, X5 has its own isolated power supply)
	K1/K3							Thyristor zero-crossing trigger output module (K1: singlechannel, K3: threechannel; K3 occupies the MIO port)
	K50/K60							Thyristor phaseangle trigger output module (K50 for 220V voltage, K60 for 380V voltage)
	K51							Thyristor phaseangle trigger output module (inductive load, suitable for 220VAC)
Alarm (ALM)	L0							Singlechannel relay output, capacity 250V/2A, standard coil, both NO and NC terminals protected by varistors
	L1							Singlechannel relay output, capacity 250V/2A, energysaving coil, only NO terminal protected by varistor
	L3							Singlechannel relay output, capacity 250V/2A, energysaving coil, only NO terminal protected by varistor
Auxiliary (AUX)	L0							Singlechannel relay output, capacity 250V/2A, standard coil, both NO and NC terminals protected by varistors
	L1							Singlechannel relay output, capacity 250V/2A, energysaving coil, only NO terminal protected by varistor
	L3							Singlechannel relay output, capacity 250V/2A, energysaving coil, only NO terminal protected by varistor
Communication (COMM)								Default power supply: 24VDC
							-24VDC	Customized power supply: 100-240VAC
Enclosure Material							-SU	Flame-Retardant Enclosure
Input Signal							-IN**	Specified Signal Input: ** is the input type code (refer to the Input Specification Table on page P03).
							-INRT	Various RTD Inputs: Default setting is PT100 input.
							-INTC	Various Thermocouple Inputs: Default setting is K-type input.
							-INAL	Universal Input: Input specification is not preset; customers can customize it.

Remarks of Model Selection:

1. AI-208 does not have a D61 panel.
2. AI-208 main output (OUTP) only supports G1 and L1.
3. AI-208 does not have an alarm interface (ALM); only an auxiliary interface (AUX) is available.
4. AI-208/218 only support thermocouple and RTD inputs.

Example of Model Selection and Explanation:

Take A-I208A1G1L3 as an example:

This is an instrument with main model AI-208, supporting thermocouple and RTD inputs, featuring programmable alarm functions. The panel dimensions are 96×96mm, with an insertion depth of 70mm. The main output is a solidstate relay drive voltage output module (DC5V/30mA), and the AUX port is equipped with an L3 module, giving the instrument two alarm channels.

Wire Diagram

Note: Due to technical upgrades or special orders, if the wiring diagram included with the instrument differs from this selection manual, please follow the wiring diagram provided with the instrument.

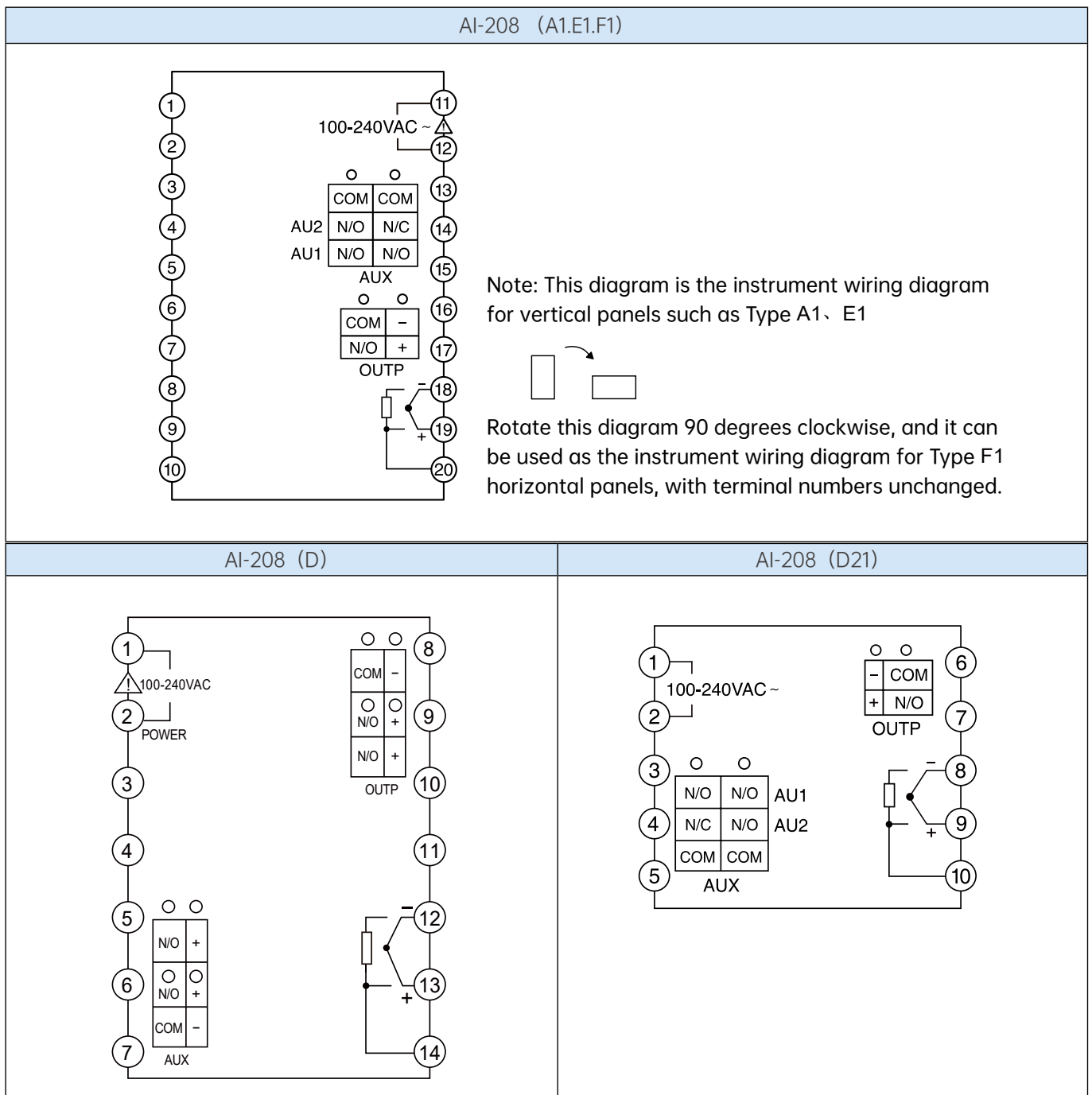

AI-218 (A1,E1,F1)

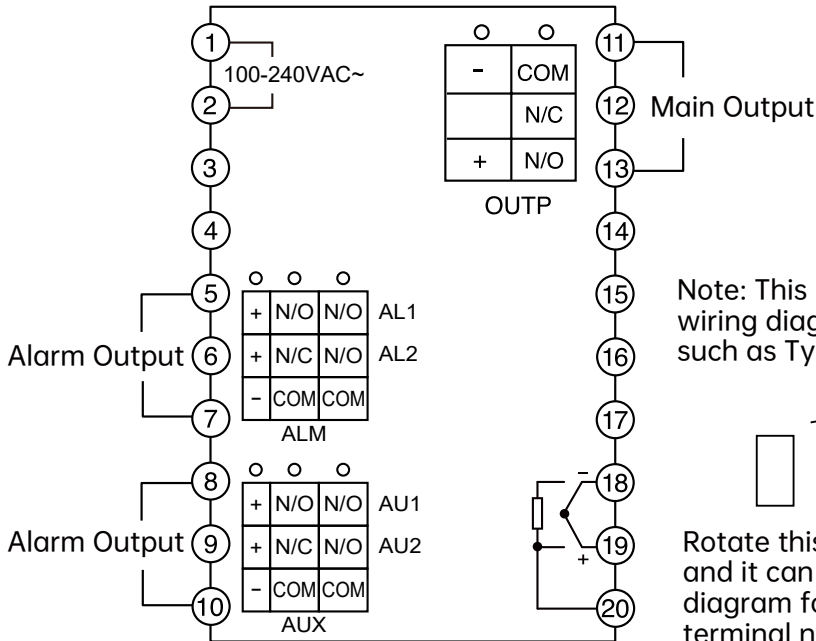

Note: This diagram is the instrument wiring diagram for vertical panels such as Type A1、 E1.

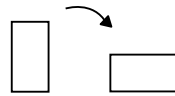

Rotate this diagram 90 degrees clockwise, and it can be used as the instrument wiring diagram for Type F1 horizontal panels, with terminal numbers unchanged.

AI-218 (D2/D21)

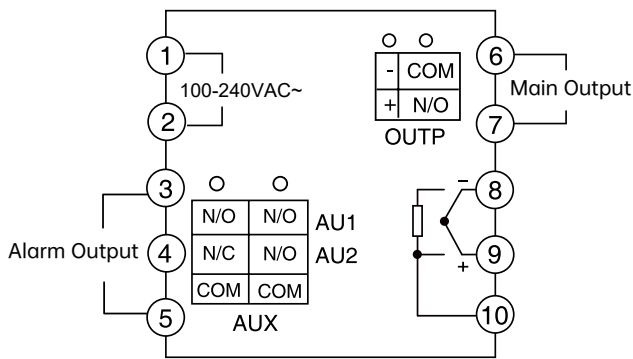

AI-218 (D61)

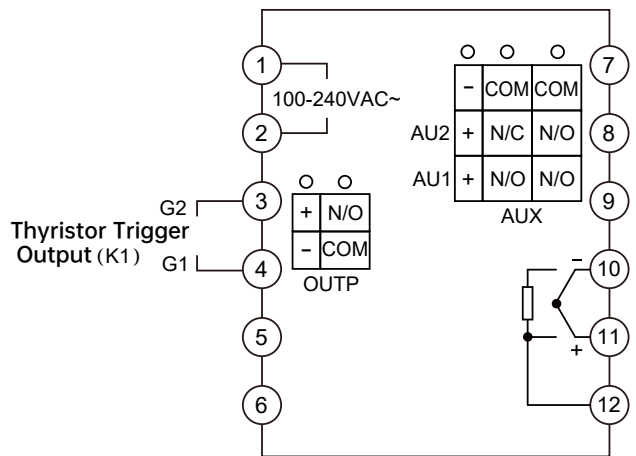

AI-226 Economical Multi-Function Intelligent Temperature Controller

AI- □ □ □ □ □ □ □ □ □ □										Description	
Model	226										Economy MultiFunction Smart Temperature Controller, Class 0.3 accuracy, dual 4digit display, 2year free warranty.
Panel Dimension (WxH)	A1										Panel Dimensions 96×96mm
	B1										Panel Dimensions 160×80mm
	C31										Panel Dimensions 80×160mm, three rows of fourdigit display
	D										Panel Dimensions 72×72mm
	D61										Panel Dimensions 48×48mm (12 wiring terminals)
	E1										Panel Dimensions 48×96mm
	F1										
Multi-I/O (MIO)	I4/I44										020mA / 420mA Current Input Module, provides 24V loop power (changed to I44 for versions V9.2 and above)
Alarm (ALM)	G1										Nonisolated Energy Saving SSR Drive Voltage Output (5V/30mA)
	L1										Relay Contact Switch Output (250V/2A)
	X3/X5										Optically Isolated Linear Current Output Module (X3 uses instrument power supply, X5 has its own isolated power supply)
	K1/K3										Thyristor Zero Crossing Trigger Output Module (K1: singlechannel; K3: threechannel, where K3 occupies the MIO port)
	K50/K60										Thyristor Phase Angle Trigger Output Module (K50 for 220V voltage; K60 for 380V voltage)
	K51										Thyristor Phase Angle Trigger Output Module (inductive load, suitable for 220VAC)
Alarm (ALM)	L0										Singlechannel relay output, capacity 250V/2A, standard coil, both NO and NC terminals protected by varistors
	L1										Single channel relay output, capacity 250V/2A, energysaving coil, only NO terminal protected by varistor
	L3										Single channel relay output, capacity 250V/2A, energysaving coil, only NO terminal protected by varistor
Auxiliary (AUX)	L0										Single channel relay output, capacity 250V/2A, standard coil, both NO and NC terminals protected by varistors
	L1										Single channel relay output, capacity 250V/2A, energy saving coil, only NO terminal protected by varistor
	L3										Single channel relay output, capacity 250V/2A, energysaving coil, only NO terminal protected by varistor
Communication (COMM)	S										Optically Isolated RS485 Communication Interface Module (uses the instrument's internal 12V isolated power supply)
	S2										Electrically Isolated RS485 Communication Interface (applicable to D series instruments)
	S4										Optically Isolated RS485 Communication Interface Module with Builtin Isolated Power Supply (does not use the instrument's internal isolated power supply)
Power											Default power supply: 24VDC
									-24VDC		Customized power supply: 100-240VAC
Enclosure Material										-SU	Enclosure made of flamer etardant material

Input Signal	-IN**	Specified Signal Input: ** is the input type code (refer to the Input Specification Table on page P03).
	-INRT	Various RTD Inputs: Default setting is PT100 input.
	-INTC	Various Thermocouple Inputs: Default setting is K-type input.
	-INAL	Universal Input: Input specification is not preset; customers can customize it.

Example of Model Selection and Explanation:

Taking AI-226A1G1L3L3S as an example:

This is an economy multifunction intelligent temperature controller/regulator with main model AI226.

Its panel dimensions are 96×96mm with an insertion depth of 70mm.

The main output is a solidstate relay drive voltage output module (DC5V/30mA).

Both the ALM and AUX ports are equipped with L3 modules, giving the instrument 4 alarm channels.

The COMM port is fitted with an S module, providing AIBUS and MODBUS communication capabilities.

Wire Diagram

Note: Due to technical upgrades or special orders, if the wiring diagram included with the instrument differs from this selection manual, please follow the wiring diagram provided with the instrument.

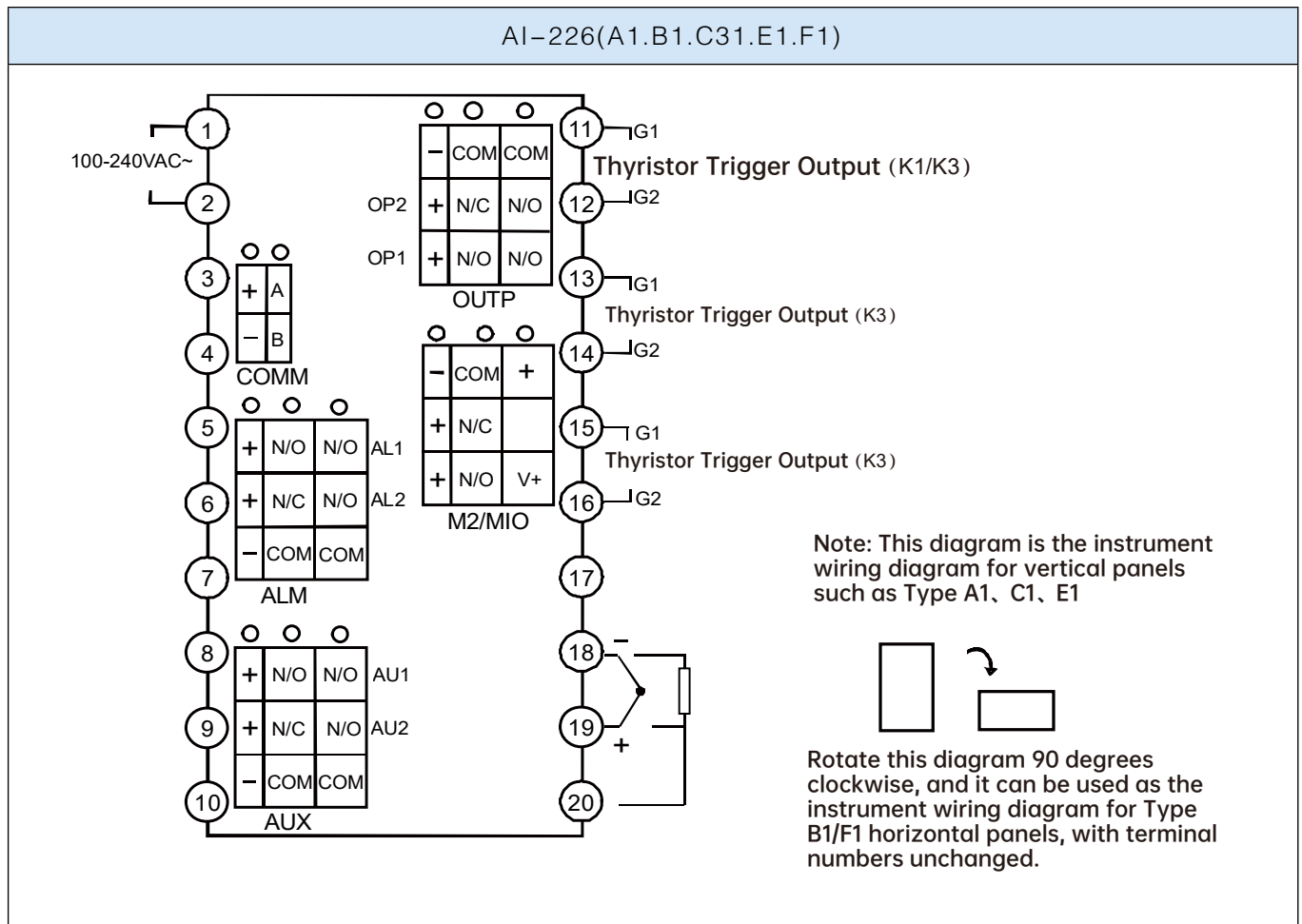

AI-226(D61)

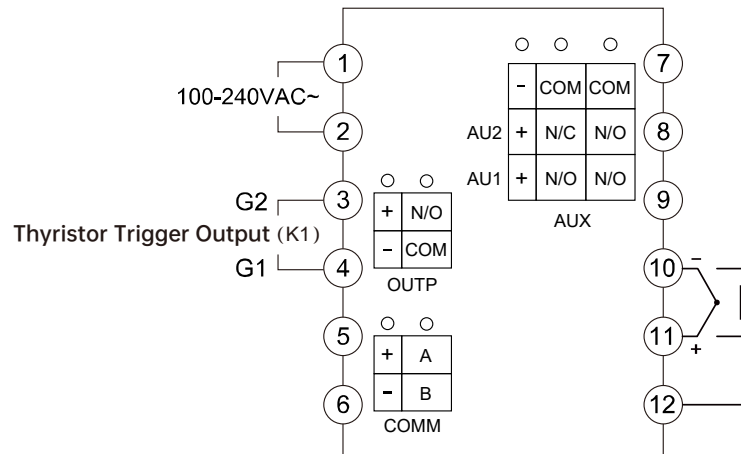

AI-211/500/501/700/701 Universal Single-Channel Display Alarm Instrument

AI- <input type="checkbox"/> <input type="checkbox"/> <input type="checkbox"/> <input type="checkbox"/> <input type="checkbox"/> <input type="checkbox"/> <input type="checkbox"/> <input type="checkbox"/> <input type="checkbox"/> <input type="checkbox"/>										Description
Model	200									Single Channel Measurement Display Alarm Instrument, Class 0.3 accuracy, singlerow display, 2year free warranty
	211									Single Channel Measurement Display Alarm Instrument, Class 0.3 accuracy, dualrow display, 2year free warranty
	500									Single Channel Measurement Display Alarm Instrument, Class 0.3 accuracy, singlerow display, 3year free warranty
	501									Single Channel Measurement Display Alarm Instrument, Class 0.3 accuracy, dualrow display, 3year free warranty
	700									Single Channel Measurement Display Alarm Instrument, Class 0.2 accuracy, singlerow display, 5year free warranty
	701									Single Channel Measurement Display Alarm Instrument, Class 0.2 accuracy, dualrow display, 5year free warranty
Panel Dimension (WxH)	A/A1									Panel Dimensions 96×96mm
	A2/A21									Panel Dimensions 96×96mm with Light Bar
	B/B1									Panel Dimensions 160×80mm
	C3/C31									Panel Dimensions 80×160mm, Three Rows of 4Digit Display
	D									Panel Dimensions 72×72mm (no MIO)
	D61									Panel Dimensions 48×48mm (no MIO, no ALM)
	E/E1									Panel Dimensions 48×96mm
	E2/E21									Panel Dimensions 48×96mm with Light Bar
	E5/E51									DIN Rail Mounting, Width 45mm, No Builtin Display, External E8 Display Unit
F/F1									Panel Dimensions 96×48mm (W × H)	

Multi-I/O (MIO)	I4/I44						0–20mA/4–20mA Current Input Module, provides 24V loop power (changed to I44 for versions V9.2 and above)
	I7						1Channel 0–5A AC Current Input Module
	I8						1Channel 0–500V AC Voltage Input Module
	I20						1Channel 0–20V DC Voltage Input Module
	I50						1Channel 0–50V DC Voltage Input Module
	I100						1Channel 0–100V DC Voltage Input Module
	I200						1Channel 0–200V DC Voltage Input Module
	I500						1Channel 0–500V DC Voltage Input Module
	I1000						1Channel 0–1000V DC Voltage Input Module
V*						V24, V12, V10 Modules: 24VDC, 12VDC, 10VDC power supply modules, respectively	
Main Output (OUTP)	X3						Optically Isolated Linear Current Output Module, uses the instrument's internal 12V power supply
	X5						Optically Isolated Linear Current Output Module, does not use the instrument's internal power supply
Alarm (ALM)	L0						LargeSize Single Channel Relay Output Module, capacity 250VAC/2A (only for AI211)
	L21						Compact SingleChannel Relay Output Module, capacity 250VAC/1A
	L3						Dual Channel Relay Output Module, two sets of normallyopen contacts, capacity 250VAC/2A
Auxiliary (AUX)	L0						Large Size Single Channel Relay Output Module, capacity 250VAC/2A (only for AI211)
	L21						Compact Single Channel Relay Output Module, capacity 250VAC/1A
	L3						Dual Channel Relay Output Module, two sets of normallyopen contacts, capacity 250VAC/2A
Communication (COMM)	S						Optically Isolated RS485 Communication Interface Module (uses the instrument's internal 12V isolated power supply)
	S2						Electrically Isolated RS485 Communication Interface (applicable to D series instruments)
	S4						Optically Isolated RS485 Communication Interface Module with Builtin Isolated Power Supply (does not use the instrument's internal isolated power supply)
Power							Default power supply: 24VDC
						-24VDC	Customized power supply: 100-240VAC
Input Signal							-IN** Specified Signal Input: ** is the input type code (refer to the Input Specification Table on page P03).
							-INRT Various RTD Inputs: Default setting is PT100 input.
							-INTC Various Thermocouple Inputs: Default setting is K-type input.
							-INAL Universal Input: Input specification is not preset; customers can customize it.

AI- □ □ □ □ □ □ □ □								Description
Model	211							SingleChannel Measurement Display Alarm Instrument, Class 0.3 accuracy, dualrow display, 2year free warrant
	500							SingleChannel Measurement Display Alarm Instrument, Class 0.3 accuracy, singlerow display, 3year free warranty
	501							SingleChannel Measurement Display Alarm Instrument, Class 0.3 accuracy, dualrow display, 3year free warranty
	700							SingleChannel Measurement Display Alarm Instrument, Class 0.2 accuracy, singlerow display, 5year free warranty
	701							SingleChannel Measurement Display Alarm Instrument, Class 0.2 accuracy, dualrow display, 5year free warranty
Panel Dimension (WxH)	D71							DIN Rail Mounting, width 22.5 mm, with builtin display, power and communication via bustype terminals
Multi-I/O (MIO)	X3							Optically Isolated Linear Current Output Module, uses the instrument's internal 12V power supply
Alarm (ALM)	L0							LargeSize SingleChannel Relay Output Module, capacity 250VAC/2A (only for AI211)
	L21							Compact SingleChannel Relay Output Module, capacity 250VAC/1A
	L3							DualChannel Relay Output Module, two sets of normallyopen contacts, capacity 250VAC/2A
Auxiliary (AUX)	L0							LargeSize SingleChannel Relay Output Module, capacity 250VAC/2A (only for AI211)
	L21							Compact SingleChannel Relay Output Module, capacity 250VAC/1A
	L3							DualChannel Relay Output Module, two sets of normallyopen contacts, capacity 250VAC/2A
Communication (COMM)	S							Optically Isolated RS485 Communication Interface Module (uses the instrument's internal 12V isolated power supply)
	S2							Electrically Isolated RS485 Communication Interface (applicable to D series instruments)
Power	-24VDC							Default power supply: 24VDC
	-220VAC							Customized power supply: 100-240VAC
Input Signal	-IN**							Specified Signal Input: ** is the input type code (refer to the Input Specication Table on page P03).
	-INRT							Various RTD Inputs: Default setting is PT100 input.
	-INTC							Various Thermocouple Inputs: Default setting is K-type input.
	-INAL							Universal Input: Input specification is not preset; customers can customize it.

Remarks of Model Selection:

- 1.Models AI-200 and AI-211 do not support 05V and 15V inputs. The main output is fixed as onoff control (typically the L1 module is selected) and cannot be used for transmission. Optional solderedmodule panelmount sizes include A1, D21, E1, F1, etc.
- 2.AI-200, 500, 700 do not support lightbar displays.
- 3.D panel instruments do not have an MIO port. The COMM port and ALM port share the same output channel. If an RS485 communication module is installed, the instrument will not have an ALM port. If alarm functionality is required, an alarm output module can be added to the AUX port.
- 4.D61 panel instruments have no MIO port or ALM port and do not support 0–5V/1–5V linear voltage input.

Taking AI-701EI44X5L3L3S as an example:

This is a singlechannel measurement display alarm instrument with dualrow display, panel dimensions of 48×96mm, and Class 0.2 measurement accuracy.

The auxiliary input port is equipped with an I44 module, indicating that the instrument can accept 0–20mA/4–20mA or twowire transmitter signals (for thermocouple or RTD inputs, no additional module is needed at the auxiliary input).

X5 indicates that the main output is an optically isolated linear current output.

Both the alarm port (ALM) and auxiliary alarm port (AUX) are fitted with L3 modules, giving the instrument four alarm outputs.

Additionally, the instrument supports RS485 communication.

Wire Diagram

Note: Due to technical upgrades or special orders, if the wiring diagram included with the instrument differs from this selection manual, please follow the wiring diagram provided with the instrument.

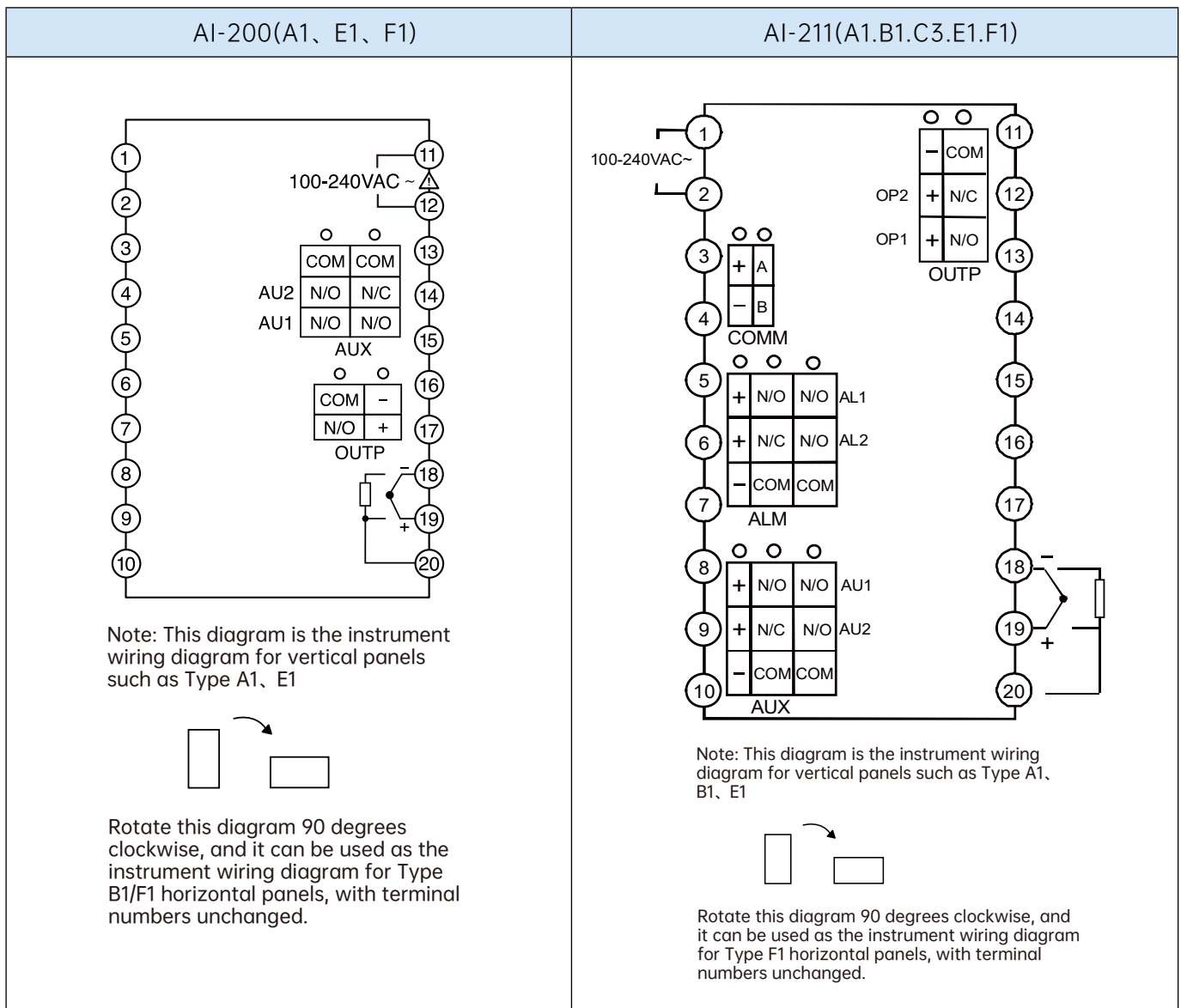

AI-211(D61)

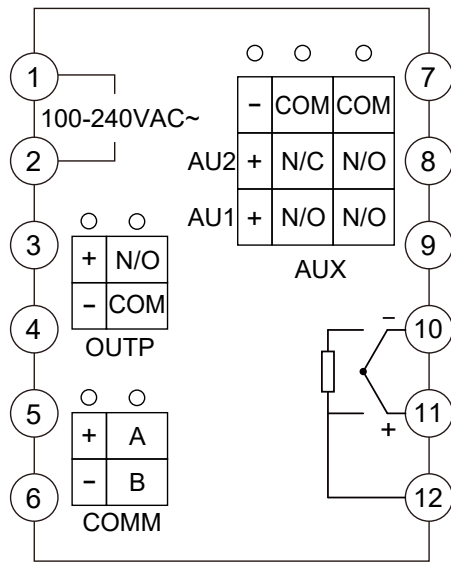

AI-500 / 501 / 700 / 701
(A.A1.A2.A10.B.B1.C3.C31.E.E1.F.F1)

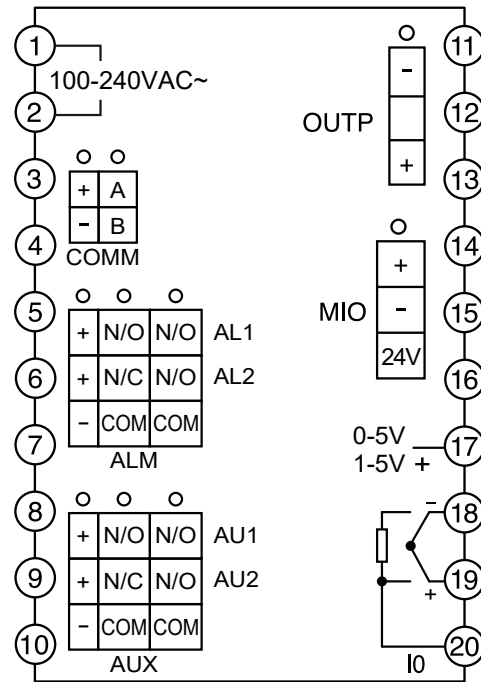

Note: This diagram is the instrument wiring diagram for vertical panels including Types A, A1, A2, A10, C, C1, E and E1.

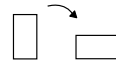

Rotate this diagram 90 degrees clockwise, and it can be used as the instrument wiring diagram for horizontal panels including Types B, B1, F and F1, with terminal numbers unchanged.

AI-500 / 501 / 700 / 701 (D)

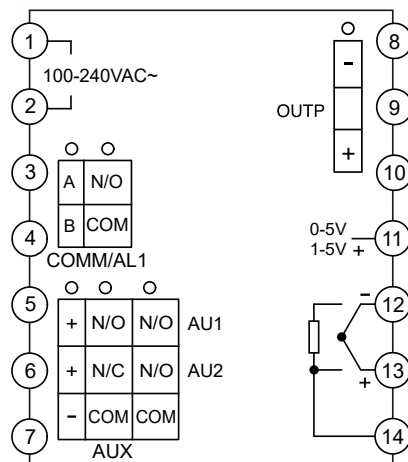

AI-500 / 501 / 700 / 701(D61)

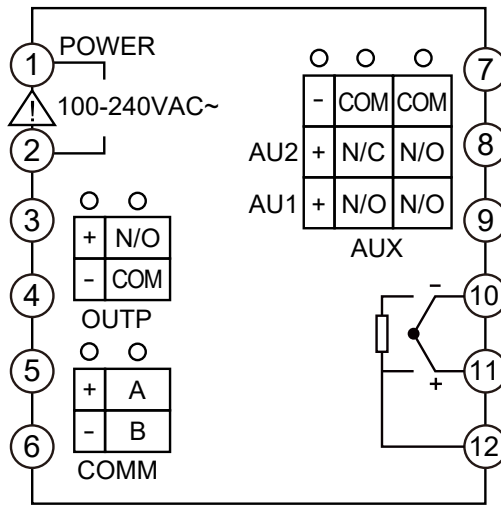

AI-500 / 501 / 700 / 701 (D71)

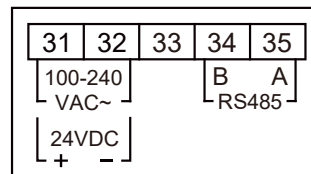
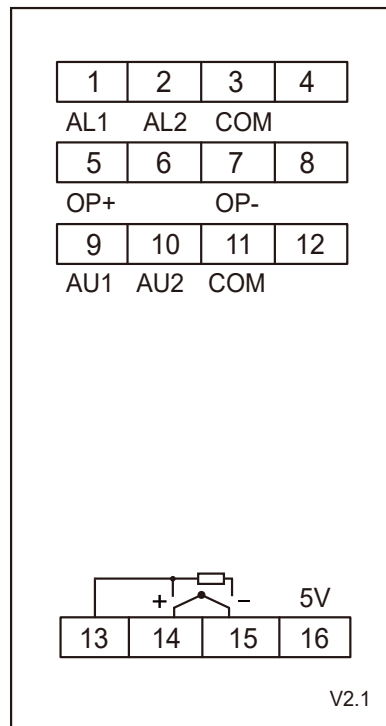

AIJK Series Phase-Shift Trigger

AI- □ □ □ □ □ □ □ □ □ □										Description
Model	733									Class 0.2 Accuracy, bumpless manual/auto switching, dual communication protocols, dedicated threephase three wire trigger output, 5 year free warranty
	733P									Based on AI-733, adds 30 segment program control function, 5 year free warranty
Panel Dimension (W×H)	A									Panel Dimensions 96×96 mm
	B									Panel Dimensions 160×80 mm (W×H)
	C									Panel Dimensions 80×160 mm (W×H)
	E									Panel Dimensions 48×96 mm (W×H)
	F									Panel Dimensions 96×48 mm (W×H)
Main Output (OUTP)	K9									ThreePhase PhaseAngle Thyristor Trigger Module
Alarm (ALM)	L21									Compact SingleChannel Relay Output Module, capacity 250 VAC/1A
	L3									Dual Channel Relay Output Module, two sets of normally open contacts, capacity 250 VAC/2 A
	G									SolidState Relay Drive Voltage Output Module (DC12 V/30 mA)
	W1/W2									Thyristor Non Contact Switch Output Module (W1: normally open, W2: normally closed)
Auxiliary (AUX)	L1									LargeSize Single Channel Relay Output Module, capacity 250 VAC/2A
	L21									Compact Single Channel Relay Output Module, capacity 250 VAC/1A
	L3									Dual Channel Relay Output Module, two sets of normally open contacts, capacity 250 VAC/2A
	G									Solid State Relay Drive Voltage Output Module (DC12 V/30 mA)
	R									RS232 Communication Interface, uses instrument's internal 12 V power supply
Communication (COMM)	I2									Digital Input Module, can be used for dual value switching, controlling program start/stop of the instrument
	S/S4									Optically Isolated RS485 Communication Interface (S uses instrument power supply; S4 has its own isolated power supply)
	S6									MODBUSRTU Protocol, Optically Isolated RS485 Communication Interface Module (using instrument's internal 12 V isolated power supply)
	S7									MODBUSRTU Protocol, Optically Isolated RS485 Communication Interface Module (using instrument's internal 24 V isolated power supply)
	X3/X5									Optically Isolated Linear Current Output Module (X3 uses instrument power supply; X5 has its own isolated power supply)
Power										Default power supply: 24VDC
									-24VDC	Customized power supply: 100-240VAC
Input Signal	-IN**									Specified Signal Input: ** is the input type code (refer to the Input Specification Table on page P03).
	-INRT									Various RTD Inputs: Default setting is PT100 input.
	-INTC									Various Thermocouple Inputs: Default setting is K-type input.
	-INAL									Universal Input: Input specification is not preset; customers can customize it.

Remarks of Model Selection:

1. The main output of AI-733 / 733P is fixed as a three-phase three-wire thyristor trigger output, which occupies the auxiliary input MIO.

Wire Diagram

Note: Due to technical upgrades or special orders, if the wiring diagram included with the instrument differs from this selection manual, please follow the wiring diagram provided with the instrument.

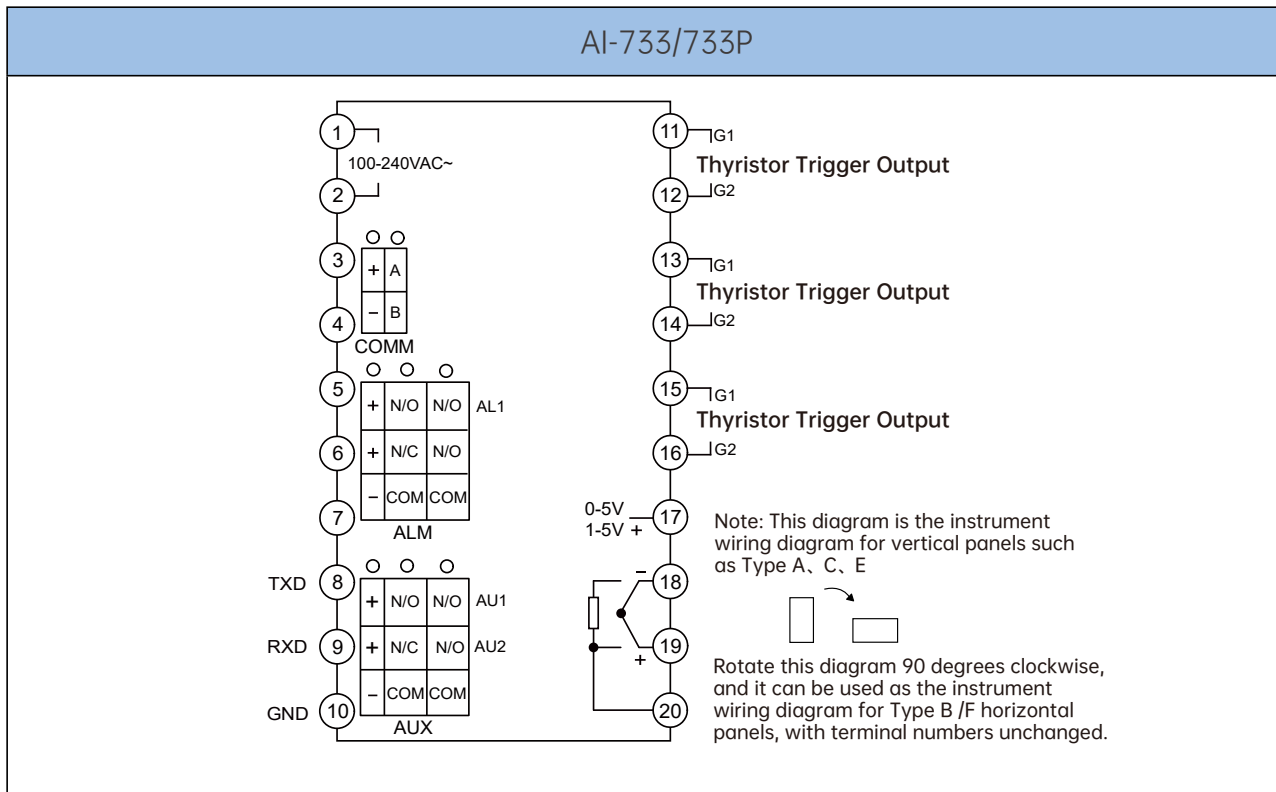

AI-601/6010/6011 Series Power Meters

Overview

The AI series power instruments include the AI-601 AC Power Meter, AI-6010 AC Voltage Meter, and AI-6011 AC Current Meter. The AI-601 AC Power Meter can also be configured via internal parameters to display current or voltage. Products are designed for a lifespan of over ten years and come with a five-year free warranty. For measuring DC voltage or DC current, Yudian's single channel measurement display alarm instruments can be selected. These support DC voltage ranges such as 0–20 VDC, 0–50 VDC, 0–100 VDC, 0–200 VDC, 0–500 VDC, 0–1000 VDC, as well as 0–5 A DC current. For detailed selection, refer to page 23.

Features

- Customized measurement scaling.
- Four programmable alarm outputs: upper limit, upperupper limit, lower limit, and lowerlower limit.
- Current output achieves 14bit D/A accuracy and highprecision transmission with temperature drift <math>< 100 \text{ ppm}/^\circ \text{C}</math>.
- RS485 communication interface for digital transmission to computers or digital paperless recorders.
- Dual row display simplifies parameter setting and allows free scaling and decimalpoint definition.

Specifications

Input Ranges

AC Current: 0–5 A (other ranges available on special order), actual display scaling freely settable.

AC Voltage: 0–500 VAC (0–250 VAC or other ranges available on special order).

Power: Display range freely defined based on the actual input AC voltage and current.

Measurement Accuracy: Class 0.2 (0.2% FS/° C ±1 digit).

Temperature Drift: ≤ 0.01% FS/° C (typical about 50 ppm/° C).

Transmission Output: With an X3 current module installed in the OUP2 position, the measured value (PV) can be transmitted with a load resistance up to 500 Ω.

Alarm Functions: Upper limit, lower limit, second upper limit, and second lower limit alarms. Relay modules can be optionally installed to output alarm signals.

Power Consumption: ≤ 5 W; ≤ 1 W when no modules are installed.

Dimensions



A (Size: 96 * 96mm)



A2 (Size: 96 * 96mm)



B (Size: 160 * 80mm)



C (Size: 80 * 160mm)

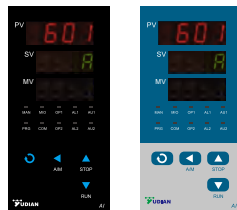

C3 (Size: 80 * 160mm)



D (Size: 72 * 72mm)

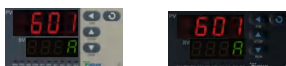

F (Size: 96 * 48mm)



E (Size: 48 * 96mm)



E2 (Size: 48 * 96mm)



E5 (DIN Rail Mounting)

AI- □ □ □ □ □ □ □ □								Description
Mode	601							AC Power Meter, 5year free warranty
	6010							AC Voltage Meter, 5year free warranty
	6011							AC Current Meter, 5year free warranty
Panel Dimension (WxH)	A							Panel Dimensions 96×96 mm
	A2							Panel Dimensions 96×96 mm with Light Bar
	B							Panel Dimensions 160×80 mm (W×H)
	B2							Panel Dimensions 160×80 mm (W×H) with Light Bar
	C							Panel Dimensions 80×160 mm (W×H)
	C3							Panel Dimensions 80×160 mm (W×H) with Light Bar
	D							Panel Dimensions 72×72 mm
	E							Panel Dimensions 48×96 mm (W×H)
	E2							Panel Dimensions 48×96 mm (W×H) with Light Bar
	E5							DIN Rail Mounting, Width 45 mm, No Builtin Display, External E8 Display Unit
F							Panel Dimensions 96×48 mm (W×H)	
Auxiliary Input (M2)	V*							V24, V12, V10 Modules: 24 VDC, 12 VDC, 10 VDC power supply modules, respectively
Main Output (OUTP)	X3							Optically Isolated Linear Current Output Module, uses instrument internal 12 V power supply
	X5							Optically Isolated Linear Current Output Module, does not use instrument internal power supply
Alarm (ALM)	L21							Compact Single Channel Relay Output Module, capacity 250 VAC/1 A
	L3							DualChannel Relay Output Module, two sets of normal yopen contacts, capacity 250 VAC/2 A
	G							Solid State Relay Drive Voltage Output Module (DC12 V/30 mA) Thyristor NonContact Switch Output Module (W1: normally open, W2: normallyclosed)
	W1/W2							Thyristor NonContact Switch Output Module (W1: normally open, W2: normally closed)
Auxiliary (AUX)	L21							Compact SingleChannel Relay Output Module, capacity 250 VAC/1 A
	L3							Dual Channel Relay Output Module, two sets of normally open contacts, capacity 250 VAC/2 A
	G							Dual Channel Relay Output Module, two sets of normally pen contacts, capacity 250 VAC/2 A
	R							RS232 Communication Interface, uses instrument internal 12 V power supply
Communication (COMM)	S							Optically Isolated RS485 Communication Interface, uses instrument power supply
	S2							Electrically Isolated RS485 Communication Interface (applicable to D series instruments)
	S4							Optically Isolated RS485 Communication Interface, does not use instrument power supply
	S6							MODBUS RTU Protocol, Optically Isolated RS485 Communication Interface Module (uses instrument internal 12 V isolated power supply)
	S7							MODBUS RTU Protocol, Optically Isolated RS485 Communication Interface Module (uses instrument internal 24 V isolated power supply)
Body & Panel Color	Q							Elegant Black
	Z							Classic Light Colour

Example of Model Selection:

AI- 601AV24X3L21L21S4 – This is an AC power meter with main model AI601. The instrument panel dimensions are 96×96 mm, equipped with 24 V loop power output. The main output is an optically isolated linear current output module, featuring two alarm channels and RS485 communication.

Wire Diagram

Note: Due to technical upgrades or special orders, if the wiring diagram included with the instrument differs from this selection manual, please follow the wiring diagram provided with the instrument.

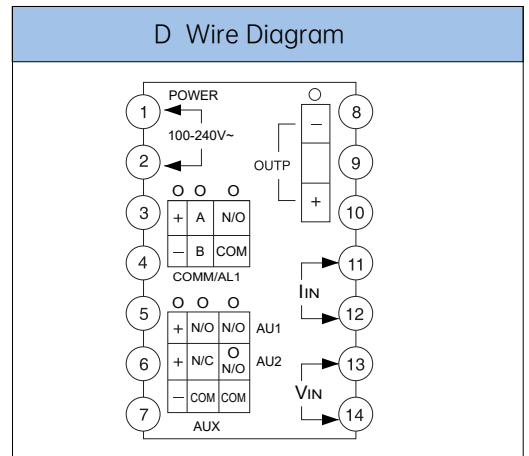
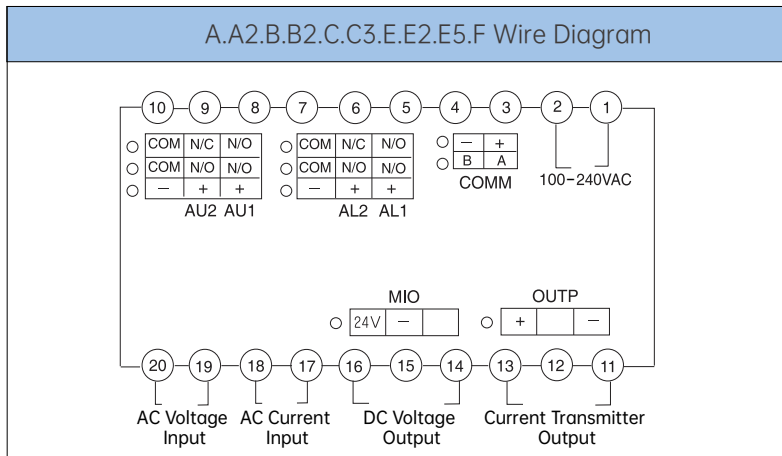

AI Series DIN Rail Mounted Digital Input / Output Module

AI-	□	□	□	□	□	□	Description
Model	3011D5						10 Point Digital Input Module (does not support optional modules M1M5)
	3013D5						8 Point Relay Output Module (does not support optional modules M1M5)
	301ME5						Digital Input/Output Combination Module, 5 year free warranty
Channel 1 (M1)	I2						SingleChannel Frequency Module
	I5						Two External Digital Inputs
	L21						Compact Single Channel Relay Output Module, capacity 250 VAC/1A
	L3						Dual Channel Relay Output Module, two sets of normally open contacts, capacity 250 VAC/2A
Channel 2 (M2)	I5						Two External Digital Inputs
	L21						Compact Single Channel Relay Output Module, capacity 250 VAC/1A
	L3						Dual Channel Relay Output Module, two sets of normally open contacts, capacity 250 VAC/2A
Channel 3 (M3)	I5						Two External Digital Inputs
	L21						Compact Single Channel Relay Output Module, capacity 250 VAC/1A
	L3						Dual Channel Relay Output Module, two sets of normally open contacts, capacity 250 VAC/2A
Channel 4 (M4)	I5						Two External Digital Inputs
	L21						Compact Single Channel Relay Output Module, capacity 250 VAC/1A
	L3						Dual Channel Relay Output Module, two sets of normally open contacts, capacity 250 VAC/2A

Channel 5 (M5)	I5		Two External Digital Inputs
	L21		Compact Single Channel Relay Output Module, capacity 250 VAC/1A
	L3		Dual Channel Relay Output Module, two sets of normally open contacts, capacity 250 VAC/2A
Communication (COMM)		S	Optically Isolated RS485 Communication Interface, uses instrument power supply
		S4	Optically Isolated RS485 Communication Interface, does not use instrument power supply
		S6	MODBUS RTU Protocol, Optically Isolated RS485 Communication Interface Module (uses instrument internal 12 V isolated power supply, currently not supported for D5 size)

Model Selection:

The AI301M has six module slots, allowing modules to be selected according to different functions to achieve digital signal input and output capabilities. The communication port (COMM) is dedicated to installing communication modules for interfacing with computers. The other slots M1, M2, M3, M4, and M5 can all accommodate twochannel digital input modules or single/dualchannel relay output modules. Additionally, M1 can also accept the I2 frequency input module.

Example of Model Selection::

Take AI-301ME5I5I5L3L3S-24VDC for an example.

AI-301M E5 I5 I5 I5 L3 L3 S -24VDC
 ① ② ③ ④ ⑤ ⑥

- 1 .The main unit model is AI301M, a digital input/output module instrument.
- 2.The panel size is 48×96 mm (mounted on a DIN rail).
- 3.Channels 1, 2, and 3 are equipped with I5 modules, providing the instrument with 6 digital inputs.
- 4.Channels 4 and 5 are equipped with L3 modules, providing the instrument with 4 digital outputs.
- 5.The alarm port (ALM) is equipped with an L21 module, providing the instrument with 1 alarm output (Normally Open + Normally Closed).
- 6.The communication port is equipped with an S module for communication with a computer.
- 7.The power supply is DC24V (if not specified, the instrument defaults to using 220V power).

Wire Diagram

Note: Due to technical upgrades or special orders, if the wiring diagram included with the instrument differs from this selection manual, please follow the wiring diagram provided with the instrument.

AI-301ME5

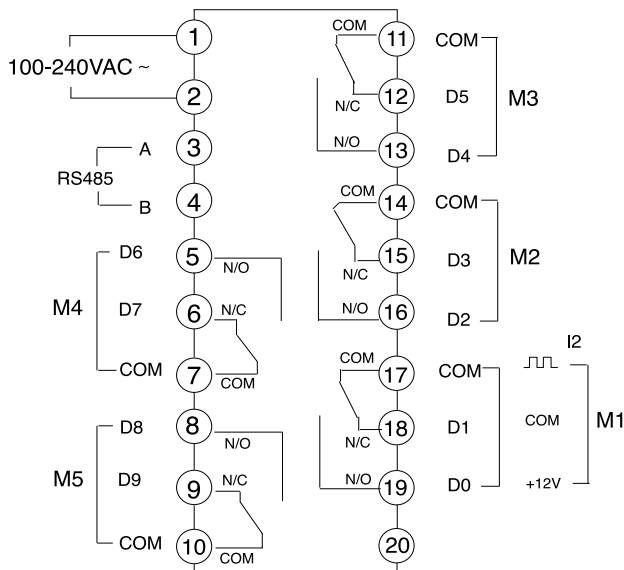

AI301ME5: The functions of M1M5 are determined by the modules installed. If a singlechannel relay module is installed, the output is only one channel, but it supports both normallyopen and normallyclosed contacts.

AI-3011D5

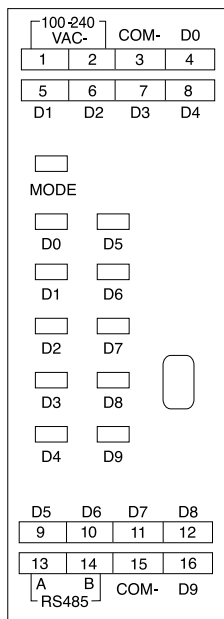

AI-3013D5

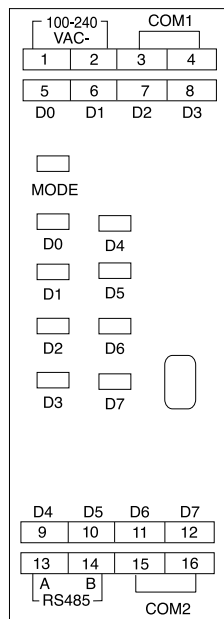

Indicator Lights for AI3011D5 and AI3013D5:
 Lights D0D9 indicate the status of the digital inputs/outputs. Lit indicates "1" (closed), and off indicates "0" (open).

Dimension

D5 Dimension

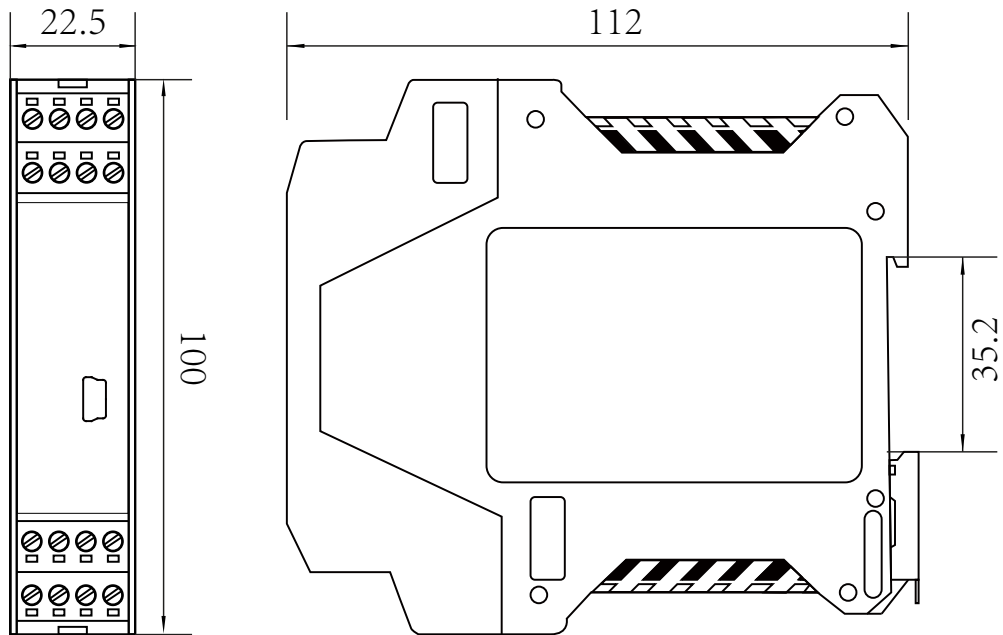

D7/E7 Dimension

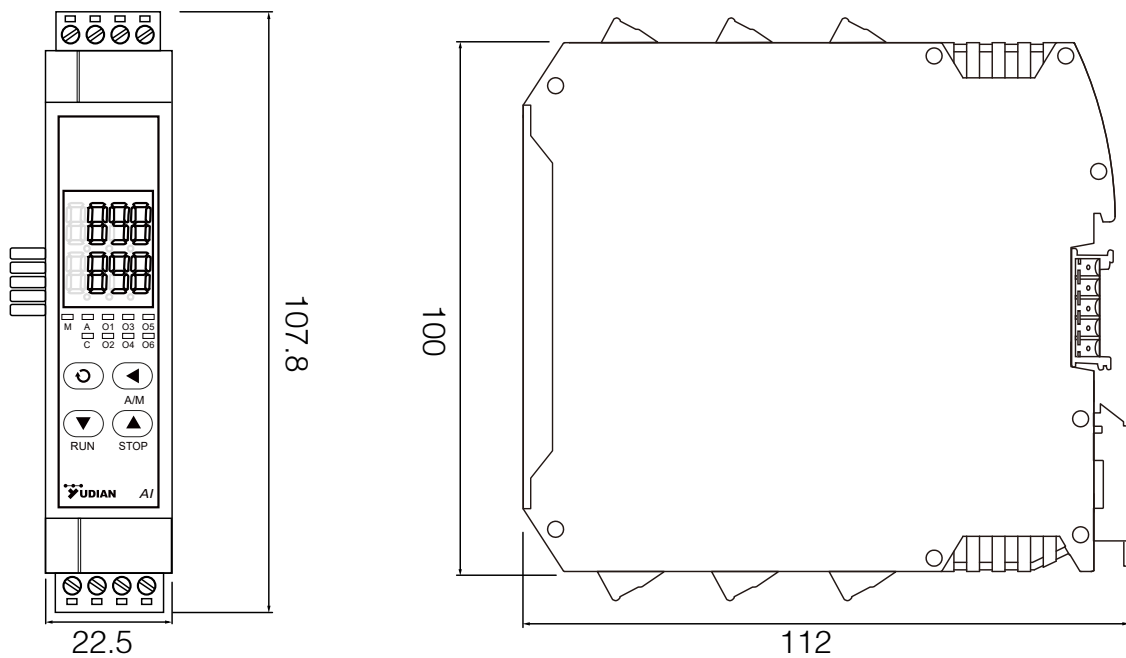

AI-302M Flashing Alarm

Overview

The AI-302M Flash Alarm Unit displays 8 channels of alarm signals using both visual and audible alerts. Its hardware is built on Yudian's AI3 platform, which is designed for processing digital (on/off) signals. This platform inherits the advanced modular design of the AI series instruments, offering high reliability and ease of mass production. It is suitable for installation on various control panels as an indicator for alarm signals.

Features

- Optically isolated alarm signal input circuit provides strong anti-interference capability and high reliability.
- Utilizes semiconductor planar light-emitting devices with high brightness, soft colours, low power consumption, and long operational life.
- Built-in buzzer; optional relay normally-open contact for alarm output.
- Features test and mute functions, operable via panel buttons or external switches connected to terminals.
- Universal power supply: compatible with 100-240VAC switching power supply or 24VDC power.
- ISO9001:2000 quality certified, ensuring reliable product quality

Specifications

- Digital Input: Optically coupled dry contact input; switch withstand voltage/current $\leq 35V/1mA$
- Digital Output: Relay contact switching: 250VAC/1A or 30VDC/1A
- Power Consumption: $\leq 2W$

Panel and Cut-out Dimension



B7 (Panel Dimension: 160×80mm, Cut-out:152×76mm)

Wire Diagram

Note: Due to technical upgrades or special orders, if the wiring diagram included with the instrument differs from this selection manual, please follow the wiring diagram provided with the instrument.

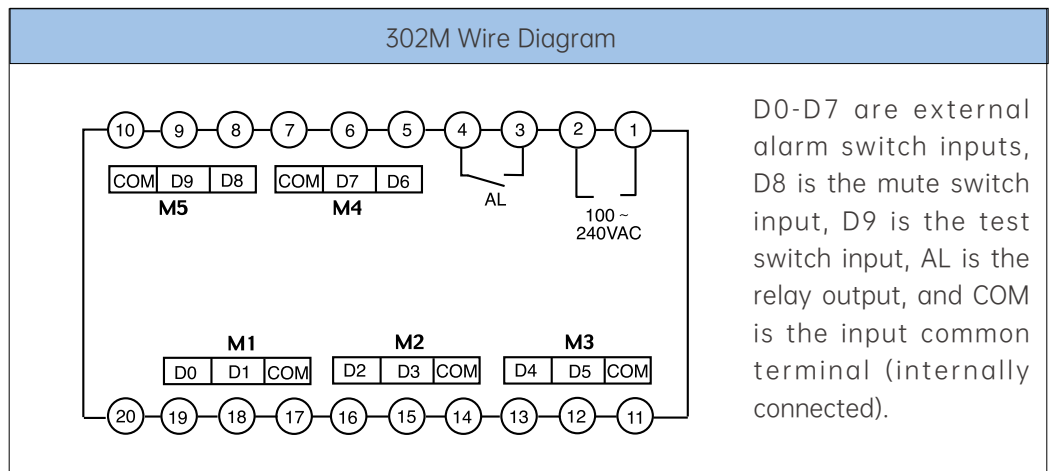

AI-3150/3170/3190 Series Split Paperless Recorder

Overview

The AI Series Split Paperless Recorder consists of a color touchscreen and AI series secondary instruments, connected via an optically isolated RS485 communication interface. This design enables centralized display/operation and paperless recording functions. The touchscreen and secondary instruments operate independently—a failure in a single instrument does not affect the touchscreen or other instruments, and a touchscreen failure does not impair the normal operation of the instruments. This meets the industrial control design principle of "centralized operation, distributed risk."



Features

- Split design: The slim touchscreen serves as the main unit mounted on the operation panel, while the secondary instruments are rail-mounted and concealed inside the cabinet, giving the overall appearance a more upscale look.
- Fully industrial touchscreen operation: Key parameter settings are completed easily within a single interface, and all setup menus are in Chinese or English, allowing customers to use it as intuitively as a smartphone.
- Extremely low self-consumption: Without any output load, each control module consumes only about 0.2–0.3W.
- Built-in datalogging function: Can display real-time trends, light bars, and historical trends, and provides record data in report format along with alarm logging.
- Stored data can be shown on the instrument's LCD screen as curves and numeric values, and can also be exported via a USB drive for further analysis on a computer.
- Compatible with various Yudian secondary instruments as lower-level units, such as single/multichannel measurement alarm instruments, intelligent PID controllers/temperature controllers, etc. Configurable on demand, purchased separately, freely combined and expanded.
- Built-in WEB server with Ethernet interface allows remote monitoring and operation of the instrument using a web browser via the Ethernet port. (Available only on 3150W/3170W/3190W.)
- P2P cloud functionality enables remote monitoring and operation via mobile devices such as smartphones and tablets without requiring a public IP address. (Available only on 3150Y/3170Y/3190Y, Simplified Chinese support and location within mainland China.)

Model Selection and Specification

AI- <input type="checkbox"/> <input type="checkbox"/> + <input type="checkbox"/> * <input type="checkbox"/>					Description
Model	3150				5inch Split Paperless Recorder, color touchscreen
	3170				7inch Split Paperless Recorder, color touchscreen
	3190				9inch Split Paperless Recorder, color touchscreen
Function		S			Standard Model
		W			Network Model – based on the Standard Model, adds a 10/100M autosensing Ethernet port, supports multiple clients simultaneously monitoring the configured screens and functions.
		Y			Cloud Model – based on the Network Model, adds P2P cloud functionality; allows remote monitoring and operation via mobile devices such as smartphones and tablets without requiring a public IP address. (Available only for Simplified Chinese support and location within mainland China.)
Lower Device			<input type="checkbox"/>		Select secondary instruments such as single/multichannel measurement alarm instruments, intelligent PID controllers/temperature controllers, etc., as lowerlevel units.
Quantity of Lower Device			<input type="checkbox"/>		Quantity of selected secondary instruments.

Example of Model Selection:

AI-3190S+AI-7368D71J7G6G6S2*5

AI-3170W+AI-706MD71J7S2*5+AI-858D71GL3S2*2

Note: For interface types, dimension drawings, and installation diagrams, please refer to page 45 in detail.

AI-3270/3290 Series True-color Touch Screen HMI

Overview

AI-3270S/3270W/3270Y/3290S/3290W/3290Y – Multifunction Configurable TrueColor HMI Touchscreen. Centered on a lowpower CPU and inheriting Yudian's classic design philosophy of low power consumption and high reliability, it embeds the powerful, flexible, and efficient Yudian HMI configuration software. It not only supports connection with Yudian's extensive AI series instruments, but is also compatible with mainstream intelligent instruments, PLCs, inverters, and other devices on the market. It can be widely applied across various industrial, scientific, and civil fields.



Features

- 800×480 widescreen display with clear, detailed image quality, providing operators with a comfortable visual experience.
- Uses long-life LED backlighting, resulting in low device power consumption, long touchscreen lifespan, high screen brightness, uniform colours, and strong visual performance.
- Multiple communication modes: Equipped with 2 serial ports (RS232 and RS485) and 2 USB ports. AI-3270W/3290W models also feature a 10/100M auto-sensing Ethernet interface.
- USB interface allows for easy storage of recorded data to a USB flash drive, enables mouse operation of the touchscreen, and can connect to devices like barcode scanners for data entry.
- AI-3270W/3290W models, when connected to a network via the Ethernet port, allow multiple computers on the same LAN to connect simultaneously through a browser, enabling display and operation of the touchscreen from a PC.
- Includes Yudian HMI configuration software (available in Simplified Chinese), offering a visual, user-friendly integrated development environment for fast and easy configuration.
- System comes with a rich library of objects and graphics, supports custom graphics, and allows importing of images in formats like BMP, JPG, and GIF for flexible creation of various industrial interfaces. Provides rich animation linking options (e.g., flashing, filling, movement) to make interfaces vivid and intuitive.
- Features powerful data processing capabilities, enabling storage and review of various data, report generation, and creation of different trend graphs.
- Offers multi-level security configuration, combining user management and security zones to ensure the operational security of configuration projects.
- Equipped with P2P cloud functionality (no public IP required, capable of intranet penetration for monitoring), allowing for remote monitoring and operation via mobile devices such as smartphones and tablets. (Available only on 3270Y/3290Y models, Simplified Chinese support and location within mainland China.)

Specifications

- Display Size: 3270S/3270W/3270Y: 7 inches
3290S/3290W/3290Y: 9 inches
- Display Color: TFT True Color
- Display Resolution: 800×480
- Backlight: Long-life LED
- Touchscreen: 4wire resistive
- Storage Capacity: 150 MB
- Power Supply Voltage: 100~240VAC/DC or 24VDC
- Power Consumption: Below 5W
- Weight: Approx. 0.7 kg
- Cooling Method: Natural air cooling
- Operating Temperature: -10 °C to 60 °C
- Operating Humidity: ≤ 90% RH
- Storage Temperature: -20 °C to 80 °C

Model Selection and Specification

AI- □ □			Description
Model	AI-3270		7-inch True Color Touchscreen HMI
	AI-3290		9-inch True Color Touchscreen HMI
Function		S	Standard Model
		W	Network Model – based on the Standard Model, adds a 10/100M autosensing Ethernet port, supports multiple clients simultaneously monitoring the configured screens and functions.
		Y	Cloud Model – based on the Network Model, adds P2P cloud functionality; allows remote monitoring and operation via mobile devices such as smartphones and tablets without requiring a public IP address. (Available only for Simplified Chinese support and location within mainland China.)

Connectors



Dimensions

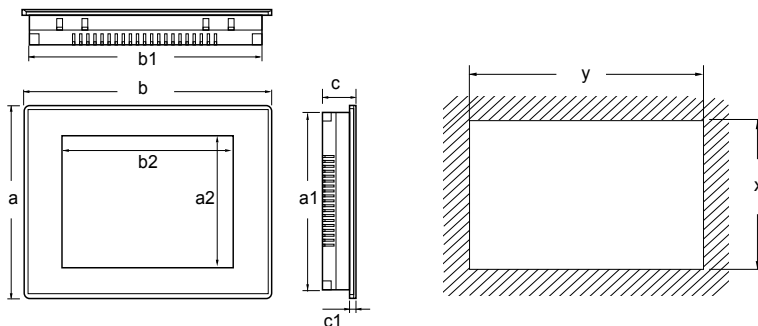

	Display Size			Outer Dimension						Cut-out Dimension	
		a2	b2	a	b	c	a1	b1	c1	x	y
3150	5 寸	64	102	105	145	100	94	133	6	96	135
3170/3270	7 寸	86	154	150	203	40	137	190	6	139	192
3190/3290	9 寸	112	198	170	231	38	158	219	6	160	221

Installation

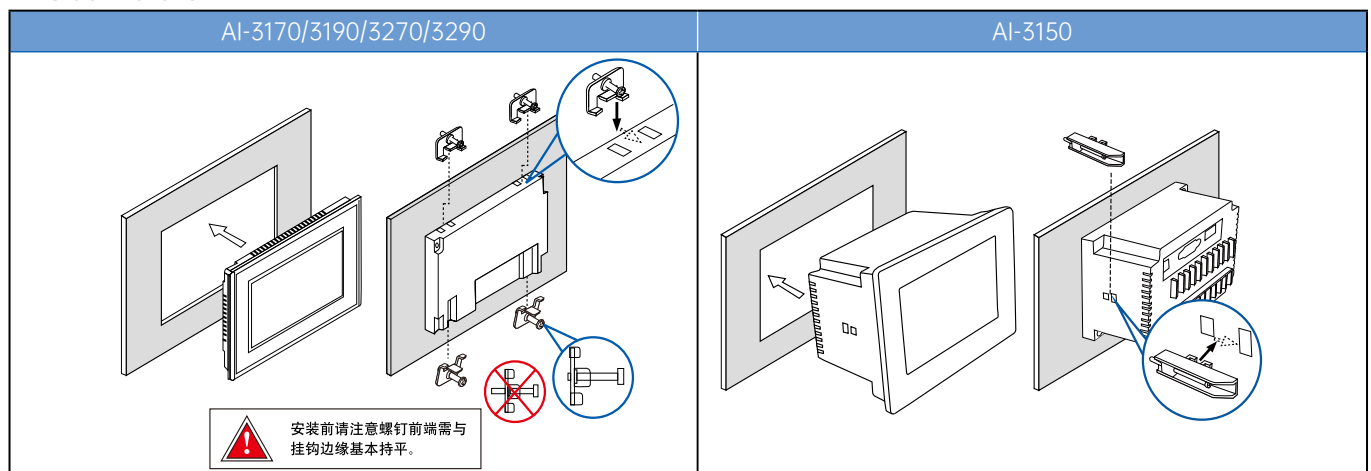

Intelligent Programmable Temperature Transmitter / Signal Isolator

Overview

AI7011/7021 Intelligent Programmable Temperature Transmitter / Signal Isolator – Its input signal can be arbitrarily programmed for thermocouples, RTDs, and linear voltage (mV) or current. The output signal is 420mA or 020mA, and the input includes digital filtering. The AI7021 can operate as two independent transmitters or signal isolators, or can be configured via parameters to function as a 1input2output transmitter or signal isolator, reducing cost and installation space while offering flexible and convenient use.



Features

- DIN rail mounting, width only 22.5 mm, occupies less cabinet space.
- Uses highperformance components, significantly reducing temperature drift and minimizing crosschannel interference.
- Digitally calibrated current output, no potentiometers, further enhancing current output accuracy and stability.
- Can be directly connected to an E8 handheld display using a special IEEE1394 cable for programming by changing different input specifications and defining transmission output ranges and etc.

Specifications

- Power Supply: 100~240VAC/50Hz +10%, -15% or optional 24VDC
Power Consumption: ≤ 3W
- Input Specifications: Thermocouples: K, S, R, E, J, T, B, N, WRe5, WRe26
RTDs: Pt100, Cu50
Linear Voltage: 0~20mV, 0~60mV, 0~100mV, 0~1V, 0.2~1V, -20~+20mV, -100~+100mV, etc.
Linear Current: 0~20mA, 4~20mA
- Measurement Range:
K (-50~+1300° C), S (-50~+1700° C), R (-50~+1700° C),
T (-200~+350° C), E (0~+1000° C), J (0~+1200° C),
B (0~+1800° C), N (-50~+1300° C),
WRe5~WRe26 (0~+2300° C), Pt100 (-200~+900° C)
- Transmission Accuracy: ±0.3%FS ±1 digit (including input and output error)
- Temperature Drift: ≤ 0.015%FS/° C (including input and output temperature drift)
- Electromagnetic Compatibility:
IEC6100044 (Electrical Fast Transient/Burst, EFT), ±4KV/5KHz;
IEC6100045 (Surge), 4KV
- Isolation Withstand Voltage:
Between power supply and signal input/output terminals: ≥ 2300VDC;
Between input and the two output channels: ≥ 200VDC
- Output Specifications: Freely definable within 0~22mA range; output voltage ≥ 11V
- Operating Environment: Temperature -10~+60° C; Humidity 0~90% RH

Note: For Btype thermocouples, measurement is possible in the 60~400 ° C range, but accuracy cannot meet the calibrated specification. Accuracy can be guaranteed in the 400~1800° C range.

Comparison among the models

AI-7011D5 Single Channel Temperature Transmitter / Signal Isolator

AI-7011D5I4 Single Channel Signal Isolator

AI-7021D5 Dual Channel Temperature Transmitter / Signal Isolator

AI-7021D5J4 Dual Channel Signal Isolator

Wire Diagram

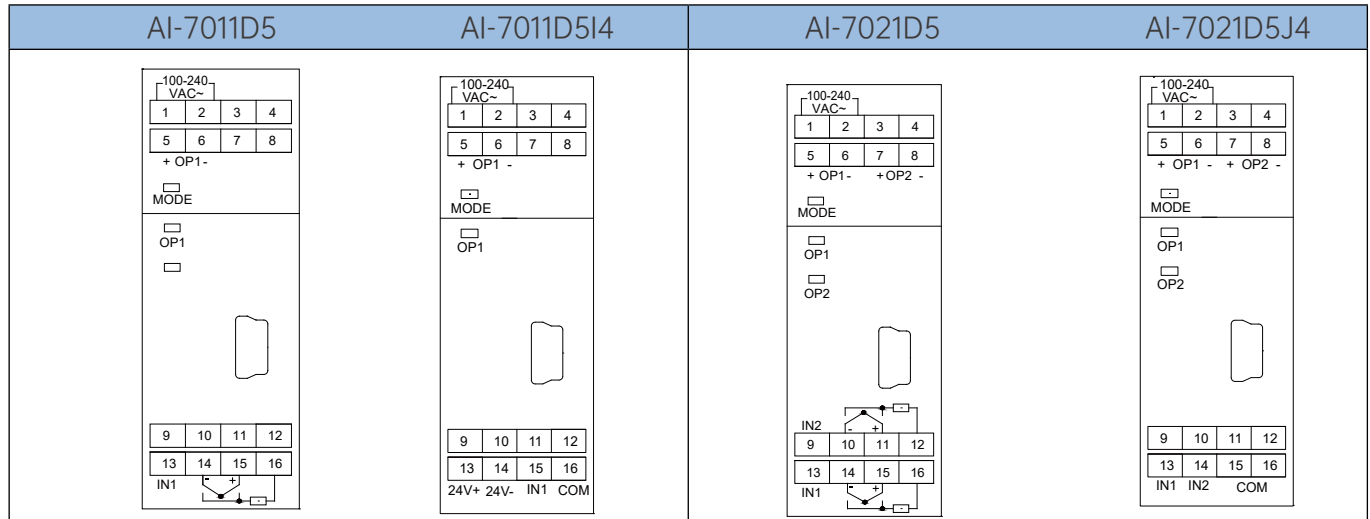

Handheld Keypad Display

Overview

E8 / E81 / E85 Series Keyboard Display is a handheld display unit designed specifically for rail mounted instruments without built in screens. It connects via a dedicated 1394 cable to display data and set parameters. This keyboard display supports hotplugging and can be used only when parameter adjustment is needed, or it can be mounted on a DIN rail for long term use as a permanent display.



Features

- E8/E85 is used for the display and keyboard operation of D5/E5 series rail mounted instruments, or for programming internal parameters of large screen touchoperation recording type instruments. (E8 is for older models, E85 for newer ones.)
- E81 is used for the display and keyboard operation of AIJK thyristor three phase phase angle trigger units.
- Can set lower level instrument parameters and display data; display and keyboard functions are fully compatible with panelmounted instruments.
- Supports hotplugging while powered.
- Can be either rail mounted or used as a handheld unit.

Description

The E8/E81/E85 handheld keyboard display uses a IEEE1394 socket and a dedicated cable to connect to rail mounted instruments without a builtin screen, enabling programming of internal instrument parameters. It can be used only when programming is required or installed on a DIN rail as a permanent display

The key components are described as follows:

- ① Upper display window – shows the measured value (PV), parameter names, etc.
- ② Lower display window – shows the setpoint (SV), alarm codes, parameter values, etc.
- ③ Set key – used to enter parameter setting mode, confirm parameter modifications, etc.
- ④ Data shift key (also functions as point control operation for programtype instruments)
- ⑤ Data decrease key (also functions as run/pause operation for program type instruments)
- ⑥ Data increase key (also functions as stop operation for program type instruments)



Dimensions

E8 /E81/E85 Overall Dimension Drawing

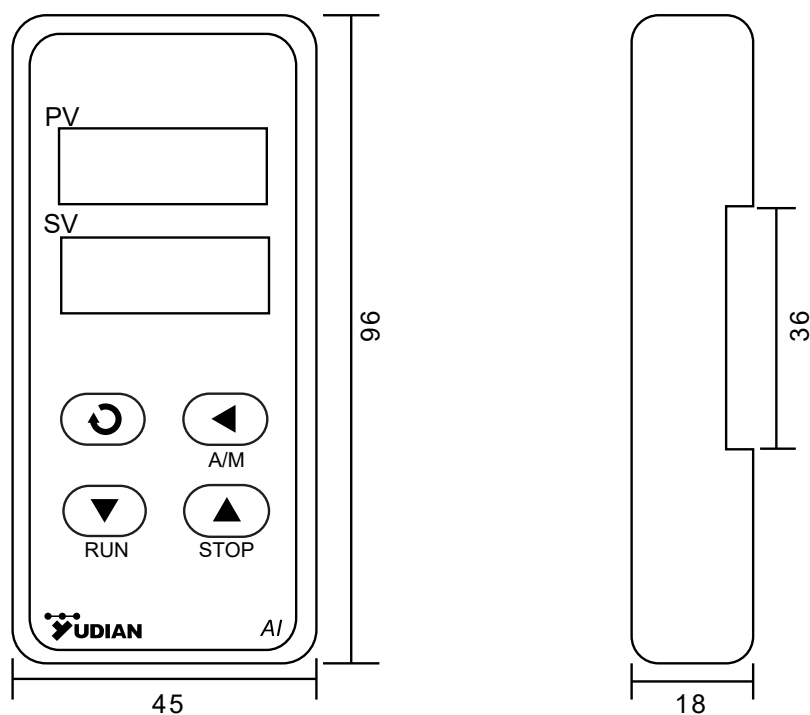

AI-5500/5600 Handheld High-Precision Digital Thermometers

Overview

The AI-5600 handheld highprecision thermometer is equipped with a 24bit A/D converter and a 16bit microcontroller, achieving a measurement accuracy as high as Class 0.02 – 5 to 25 times higher than typical handheld thermometers on the market. It provides metrologygrade measurement accuracy, suitable for verifying the true temperature of equipment, and can be widely used in production, research, laboratories, and other scenarios requiring handheld precision temperature measurement. The AI-5500 is the general purpose model, offering Class 0.1 accuracy.



Features

- Wide input compatibility: Accepts Pt100, Pt1000, Cu50, Cu100, K, S, E, T, J, R, B, N, as well as Ω , mV, and mA signals. For thermocouples, three compensation modes are available: internal, external, and manual.
- Mathematical/statistical measurement: In addition to the basic measured value, it simultaneously displays relative value, maximum, minimum, average, peaktopeak, standard deviation, and sample count.
- Sixdigit display with configurable resolution: Resolution up to 0.001 °C (for RTDs) or 0.01 °C (for K/E/J/T/N thermocouples).
- Four display units for RTDs and thermocouples including Ω , mV, °C, °F or K.
- Low power consumption: Powered by three AA alkaline batteries; with backlight off, continuous operation up to 1500 hours (typical).
- Upper and lower alarm settings, user calibration function.

Model Selection and Specifications

Model	AI-5500	AI-5600
Input Specification	Pt100、K、S、E、T、J、R、B、N	Pt100、Pt1000、Cu50、Cu100、 Ω 、mA、mV、K、S、E、T、J、R、B、N
Sampling Rate	For Pt100 and thermocouples with MAN (manual) compensation, the sampling rate is 2.5 times/s. For thermocouples with INT/EXT (internal/external) compensation, the sampling rate is 2.0 times/s.	Thermocouple sampling rate up to 12.1 times/s. Sampling rate for other input signals up to 13.2 times/s
Power Supply and Power Consumption	Power supply: 3 × 1.5V AA batteries Operating current: With backlight off ≈ 1.3 mA With backlight on ≈ 27 mA	Power supply: 3 × 1.5V AA batteries. Operating current: With backlight off ≤ 1.5 mA, With backlight on ≈ 27 mA.
Operating Environmental Conditions	Temperature: 0 ~ 50 °C Relative Humidity: ≤ 85 %	
Dimensions and Weight	Dimensions: 155 × 70 × 30 mm Weight: Approx. 0.25 kg (including batteries)	

Bundled Accessories	1.K-type Class I thermocouple flexiblewire with plug – 1 piece	1.K-type Class I thermocouple flexible 1 2.Fourwire resistance measurement cable – 1 piece
Optional Accessories (Additional cost required)	1.Precision platinum resistance probe, Class A, fourwire connector, with handle. 2.Precision thermocouple probe, Ktype, Class I , with handle. 3.4wire resistance measurement cable (can be used for calibrating the instrument's RTD input and for thermocouple EXT compensation wiring). 4.2wire connector mV measurement cable (can be used for calibrating the instrument's thermocouple input).	1.Precision Platinum Resistance Probe, Class A, 4-Wire Connector, with handle 2.Precision Thermocouple Probe, K-Type, Class I, with handle

AIJK Series Phase Angle Triggers

Overview

The AIJK series phase angle triggers are intelligent triggers utilizing microcontroller technology, offering powerful functionality and high reliability. They are suitable for various industrial furnaces such as those using resistance wires, siliconcarbide rods, or loads with transformerstepdown siliconmolybdenum rods and tungsten filaments, and can also be used for motor softstart control.



Features

- Compatible with 0-20 mA (0-5 V) / 420 mA (1-5 V) input signals.
- Uses computerbased linearized power correction; when the load is resistive, the output power is proportional to the input signal.
- Automatic synchronization – no phasesequene alignment is required when connecting thyristor trigger lines; AIJK-30 does not even require polarity alignment.
- Triggerphase shift adjustment – parameters can be set via the E81 handheld unit to shift the trigger phase for singlephase, twophase, or overall adjustment, correcting input signal magnitude and maximum output limits.
- Adjustable softstart / softstop with configurable ram pup/ramp down times, suitable for siliconmolybdenum rods, tungsten filaments, motors, and inductive loads.
- Employs full optical isolation and "burnproof" technology, ensuring very high reliability and minimal interference to the input side.
- Builtin switching power supply – can be powered directly from 220 VAC; AIJK30 / AIJK33 also provide both 5 V and 24 V DC outputs.

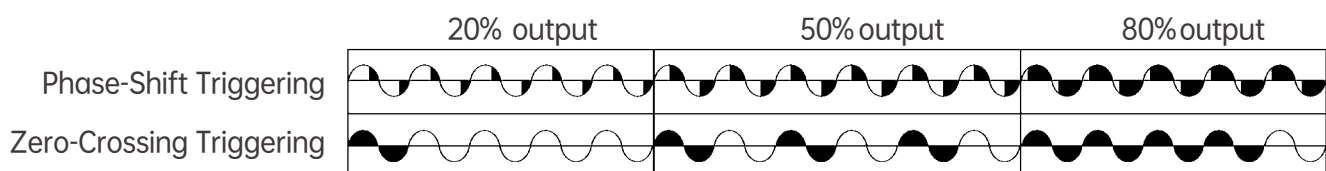

The Difference Between Phase-Shift Triggering and Zero-Crossing Triggering (The black part represents the load current)

Model Selection and Specification

Model	Load Characteristics	Wiring Method
AIJK-10 SinglePhase PhaseAngle Trigger	Resistive & Inductive	Dedicated for singlephase 220V/380V
AIJK-30 Three-Phase Phase-Angle Trigger	Resistive	Threephase fourwire, twophase, and singlephase
AIJK-30J ThreePhase PhaseAngle Trigger	Resistive	Threephase fourwire, twophase, and singlephase
AIJK-33 ThreePhase PhaseAngle Trigger	Resistive & Inductive	Dedicated for three-phase three-wire (semi-controlled and fully-controlled circuits)
AIJK-33J ThreePhase PhaseAngle Trigger	Resistive & Inductive	Dedicated for three-phase three-wire (semi-controlled and fully-controlled circuits)
AIJK-36 ThreePhase PhaseAngle Trigger	Resistive and inductive	Three-phase three-wire dedicated, suitable for controlling various thyristor power modules below 320A, connectable to E81 for parameter setting

Note: AIJK30J and AIJK33J are based on AIJK30 and AIJK33, respectively, but do not include the 24 VDC output or alarm output

SSR Solid State Relay

Overview

The SSR series compact solidstate relays employ a constant current drive circuit typically used in high end relays, with a typical drive current maintained at 56 mA, resulting in low power consumption and high reliability. Combined with an optically coupled zero crossing trigger, they offer advantages such as minimal grid interference and high isolation withstand voltage. The output incorporates a varistor to absorb grid voltage spikes, ensuring low leakage current and long term reliable operation.



Technical Specifications

- Control Input Voltage: 4 V ~ 32 V
- Control Input Current: ≤ 8 mA
- TurnOff Voltage: ≥ 1.2 V
- Control Mode: Zero crossing trigger
- OnState Voltage Drop: ≤ 1.2 V
- Leakage Current: ≤ 2 mA
- Response Time: < 10 ms
- Mounting Method: Bolt fixing
- Insulation Strength: ≥ 2500 V
- Insulation Resistance: ≥ 100 MΩ
- Voltage Rise Rate dv/dt: ≥ 500 V/μs
- Operation Indicator: LED lamp
- Operating Temperature: -20 °C ~ 80 °C
- Enclosure: Flameretardant, insulated
- Weight: 85 g

Model Selection and Ratings

Models	Rated Current	Rated Working Voltage	Triggering Voltage
SSR15	15A	24~240VAC	4~32V
SSR20	20A	24~240VAC	4~32V
SSR20H	20A	24~415VAC	4~32V
SSR20GW	20A	24~240VAC	4~32V
SSR25	25A	24~240VAC	4~32V
SSR40	40A	24~240VAC	4~32V
SSR40H	40A	24~415VAC	4~32V
SSR40GW	40A	24~240VAC	4~32V
SSR40HGW	40A	24~415VAC	4~32V
SSR60NH	60A	24~415VAC	4~32V
SSR80NH	80A	24~415VAC	4~32V

Note: GW indicates that the SSR operating temperature can reach over 100 °C, and a heat sink can be optionally configured. Model specifications are as follows:

SR50 Heat Sink (suitable for thyristors and solid state relays with actual operating currents below 50 A, natural cooling).

R75 Heat Sink (suitable for thyristors with natural cooling below 75 A, and forced air cooled thyristors below 160 A).

Installation Dimensions

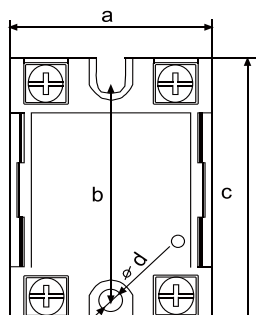

Model	a	b	c	d
SSR15	42	46	58	5.5
SSR20	42	46	58	5.5
SSR25	42	46	58	5.5
SSR40	42	46	58	5.5
SSR60	46	49	63	5.5
SSR80	46	49	63	5.5

Wire Diagram

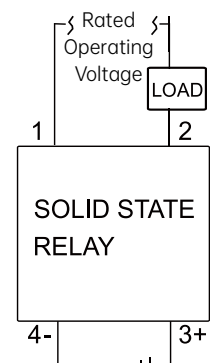

Transmitter Current Input Isolating Safety Barrier

Overview

It provides isolated DC power to transmitters located in hazardous field areas, detects the 4–20 mA current signal from the transmitter, and after isolation and interference suppression, outputs a DC signal to the safetyside control system or other instruments.

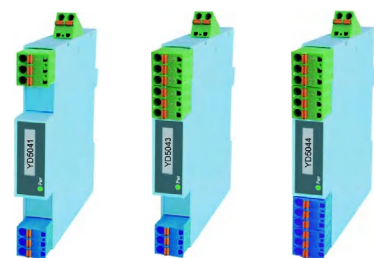

YD5041 [1In,1Out] YD5043 [1 In, 2 Out] YD5044 [2 In, 2 Out]

Features

- ▶ Powered by an independent DC power supply, with isolation between the power supply, input, and output
- ▶ Standard 35mm DIN rail clipon mounting. Plugin terminal blocks with springloaded connections.

Specifications

- ▶ Power Supply
 - Supply Voltage Range: 20–30 VDC
 - Rated Supply Voltage: 24 VDC
 - Current Consumption (at 24 VDC):
 - < 50 mA (1in 1out)
 - < 60 mA (1in 2out)
 - < 110 mA (2in 2out)
- ▶ Input from Hazardous Area
 - Input Signal: Transmitter current signal 4–20 mA
 - Input Impedance: 24 Ω
 - Power to Transmitter: ≥ 16 VDC
 - Maximum Input Current: Approx. 24 mA
- ▶ Output to Safe Area
 - Output Current: 4–20 mA; 0–20 mA; 0–10 mA; other specified currents
 - Output Voltage: 1–5 V; 0–5 V; 0–10 V; other specified voltages
 - Load Resistance:
 - For 4–20 mA output: $\leq 350 \Omega$ (factory default)
 - For 1–5 V output: $\geq 100 \text{ k}\Omega$
- ▶ General Parameters
 - Standard Accuracy: $\pm 0.1 \%$
 - Temperature Drift: $\pm 0.015 \%$ / $^{\circ}\text{C}$
 - Response Time: < 10 ms
 - Isolation Capability: 2.5 KV between input/output power, 1 min, 50 Hz
 - Insulation Resistance: $\geq 100 \text{ M}\Omega$ / 500 VDC between input/output power
 - Enclosure Material: PC (polycarbonate)
 - Dimensions: 16 × 116 × 110 (mm)
 - Operating Ambient Temperature: -20°C to $+60^{\circ}\text{C}$
 - Suitable for Connected Field Devices and Hazardous Areas: Twowire or threewire transmitters. Zone 0, 1, 2; IIA, IIB, IIC hazardous areas.
- ▶ Explosion Proof Rating Marking: [Exia Ga] IIC

Model Selection and Specifications

▶ Model and Code Structure

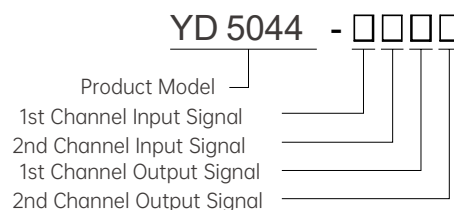
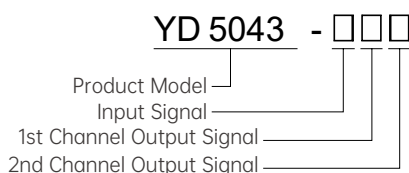
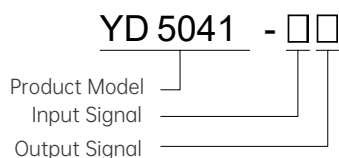

▶ Code

Output	Code
4~20mA (with Power Supply)	P

Output			
Current Signal	Code	Voltage Signal	Code
4~20mA	A	1~5V	1
0~20mA	B	0~5V	2
0~10mA	C	0~10V	3
Designated Current	Z	Designated Voltage	9

Wire Diagram

Terminal Wiring: Use solid or stranded wire with a cross section of 0.5 ~ 2.5 mm².

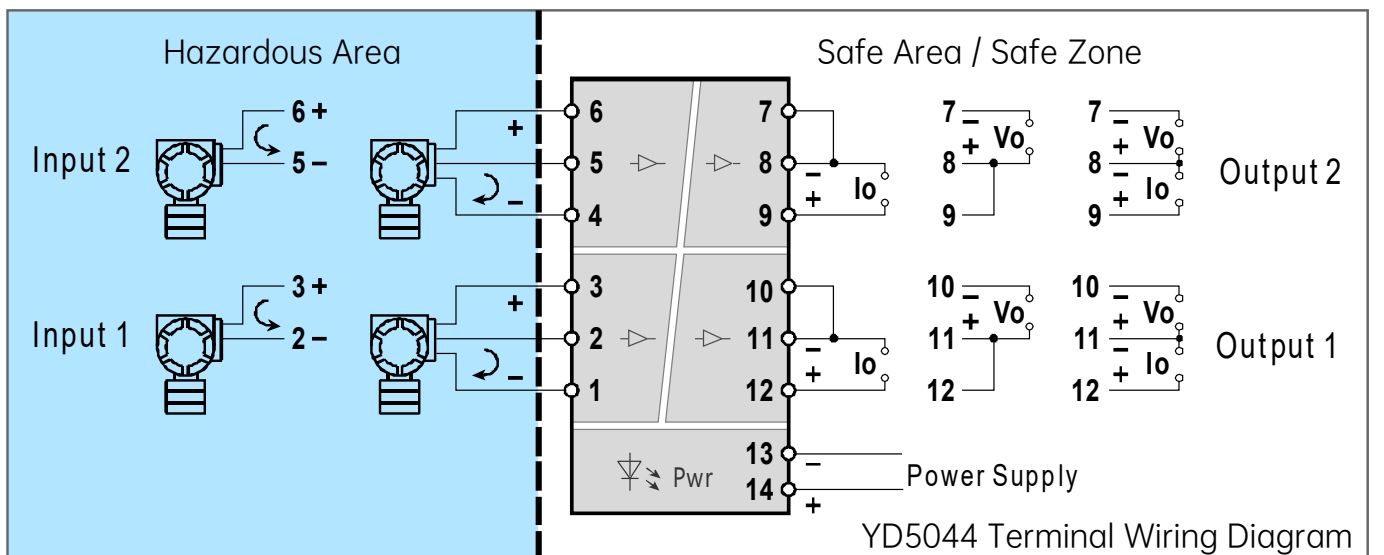
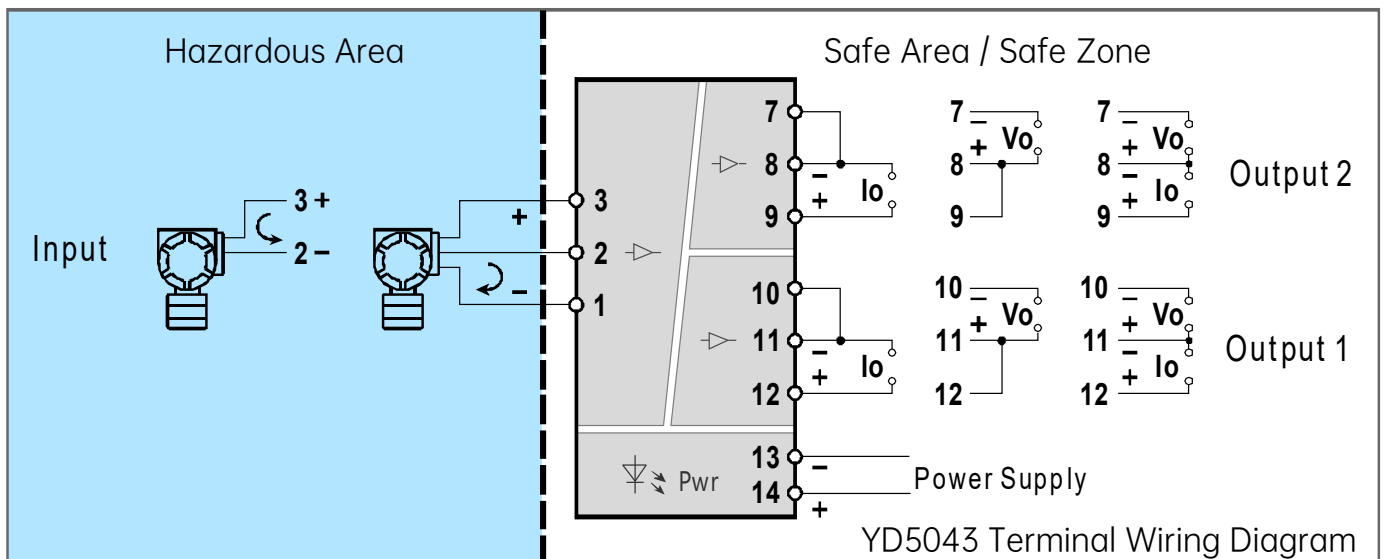
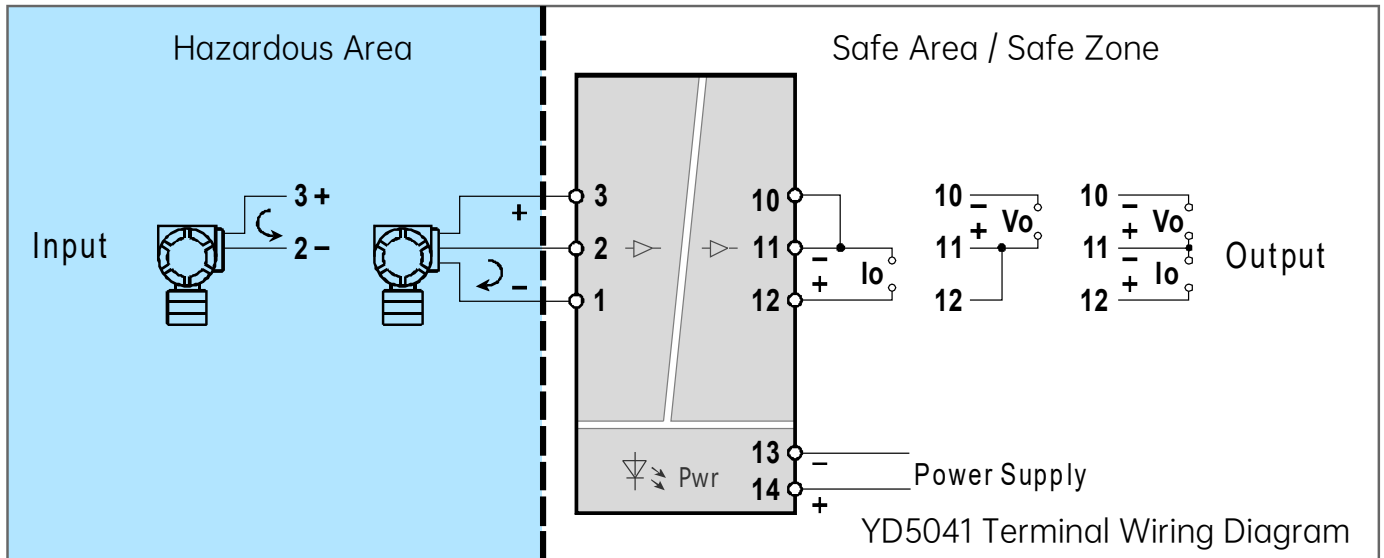

DC Signal Input Isolating Safety Barrier

Overview

The unit isolates and processes DC signals from various field devices located in hazardous areas. After isolation and interference suppression, it outputs standardized DC signals to the safetyside control system or other instruments.

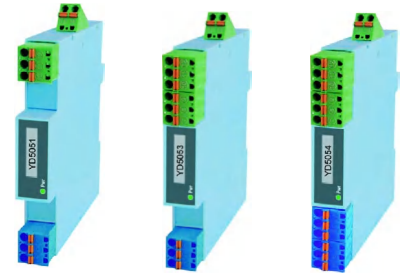

YD5051
[1 In, 1 Out]

YD5053
[1In, 2 Out]

YD5054
[2 In, 2 Out]

Features

- ▶ Powered by an independent DC power supply, with isolation between the power supply, input, and output.
- ▶ Standard 35 mm DIN rail clip on mounting. Plugin terminal blocks with springloaded connections.

Technical Specifications

- ▶ Power Supply
 - Supply Voltage Range: 20–30 VDC
 - Rated Supply Voltage: 24 VDC
 - Current Consumption (at 24 VDC):
 - < 25 mA (1in 1out)
 - < 40 mA (1in 2out)
 - < 50 mA (2in 2out)
- ▶ Input from Hazardous Area
 - Input Current: 4–20 mA; 0–20 mA; 0–10 mA; other specified currents
 - Input Voltage: 1–5 V; 0–5 V; 0–10 V; other specified voltages
 - Input Impedance: 24 Ω (current input); ≥ 500 kΩ (voltage input)
- ▶ Output to Safe Area
 - Output Current: 4–20 mA; 0–20 mA; 0–10 mA; other specified currents
 - Output Voltage: 1–5 V; 0–5 V; 0–10 V; other specified voltages
 - Load Resistance:
 - For 4–20 mA output: ≤ 350 Ω (factory default)
 - For 1–5 V output: ≥ 100 kΩ

▶ General Parameters

- Standard Accuracy: ±0.1%
- Temperature Drift: ±0.015%/°C
- Response Time: <10 ms
- Isolation Withstand Voltage: 2.5 kV between input/output power, 1 min, 50 Hz
- Insulation Resistance: ≥100 MΩ / 500 VDC between input/output power
- Enclosure Material: PC (Polycarbonate)
- Dimensions: 16 × 116 × 110 (mm)
- Operating Ambient Temperature: -20° C to +60° C
- Suitable for Connected Field Devices and Hazardous Areas: Various DC signal source devices. Zones 0, 1, 2; IIA, IIB, IIC hazardous areas.

▶ Explosion-Proof Rating Marking: [Exia Ga]IIC

Model Selection and Specifications

▶ Model and Code Structure

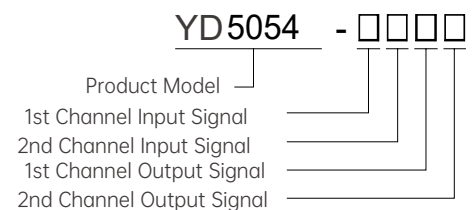
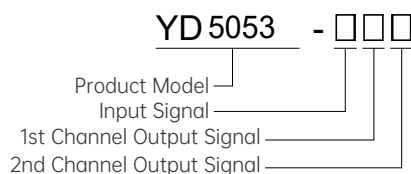
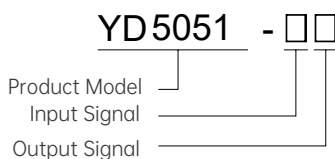

▶ Code

Input			
Current Signal	Code	Voltage Signal	Code
4~20mA	A	1~5V	1
0~20mA	B	0~5V	2
0~10mA	C	0~10V	3
Designated Current	Z	Designated Voltage	9

Output			
Current Signal	Code	Voltage Signal	Code
4~20mA	A	1~5V	1
0~20mA	B	0~5V	2
0~10mA	C	0~10V	3
Designated Current	Z	Designated Voltage	9

Wiring Diagram

Terminal Wiring: Use solid or stranded wire with a cross section of 0.5 to 2.5 mm².

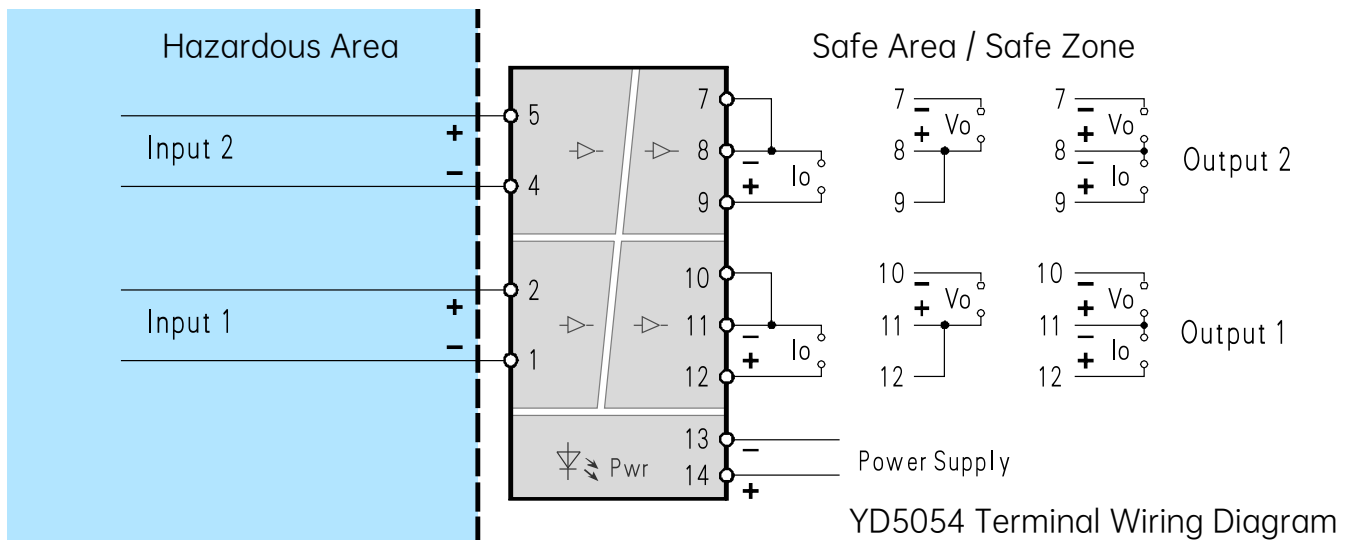
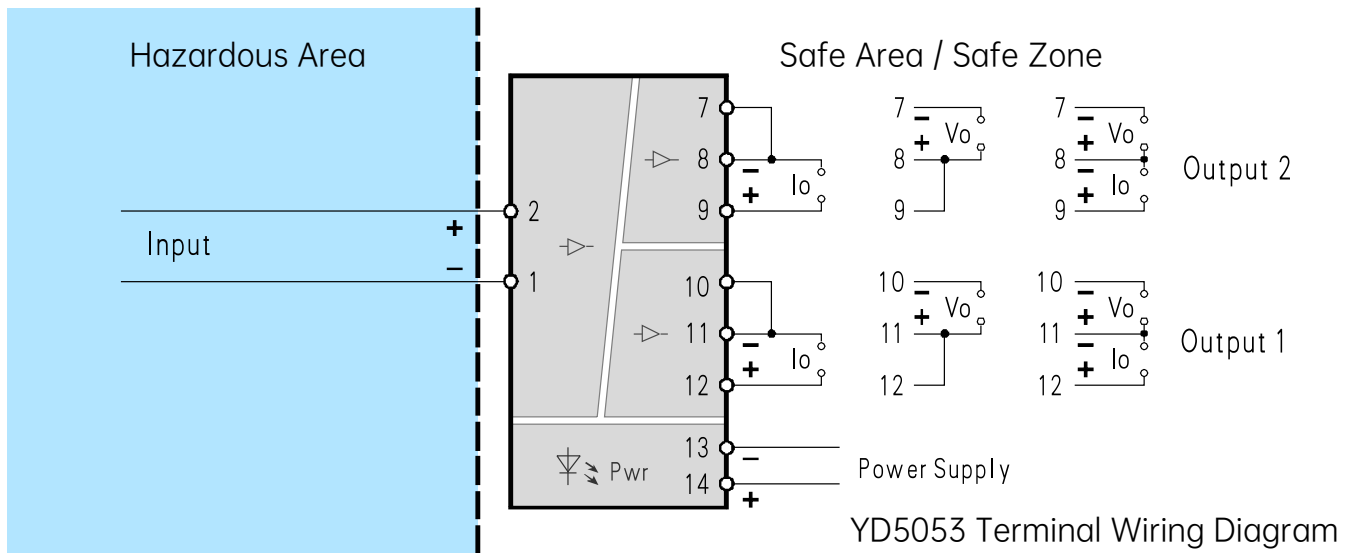
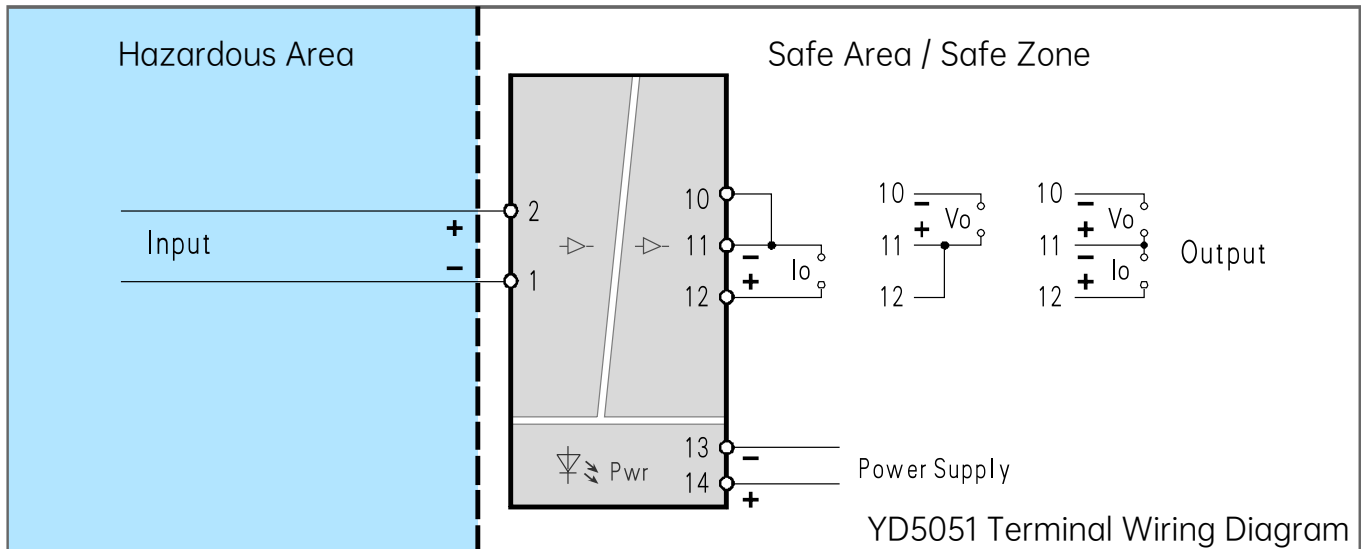

DC Signal Output Isolating Safety Barrier

Overview

Accepts DC current signals (4–20 mA) from DCS/PLC systems or other controllers located in the safe area, performs isolation and transmission, and outputs DC current (4–20 mA) to drive intrinsically safe field instruments such as electrical converters, valve positioners, and display devices in hazardous areas.

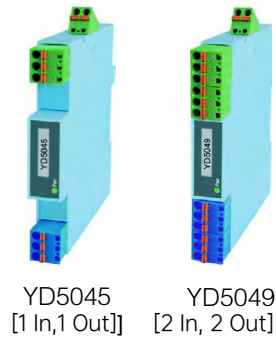

Features

- Powered by an independent DC power supply, with isolation between the power supply, input, and output.
- Standard 35 mm DIN rail clip-on mounting. Plugin terminal blocks with spring loaded connections.

Technical Specifications

- Power Supply
 - Supply Voltage Range: 20–30 VDC
 - Rated Supply Voltage: 24 VDC
 - Current Consumption (at 24 VDC):
 - < 30 mA (1in 1out)
 - < 65 mA (2in 2out)
- Input from Safe Area
 - Input Signal: 4–20 mA
 - Input Impedance: 24 Ω
 - Input Voltage Drop: < 4 V at 20 mA
- Output to Hazardous Area
 - Output Current Signal: 4–20 mA
 - Current Output Load: ≤ 550 Ω (factory default)

- General Parameters
 - Standard Accuracy: ±0.1 %
 - Temperature Drift: ±0.015 %/° C
 - Response Time: < 10 ms
 - Isolation Capability: 2.5 kV between input/output/power, 1 min, 50 Hz
 - Insulation Resistance: ≥ 100 MΩ / 500 VDC between input/output/power
 - Enclosure Material: PC (polycarbonate)
 - Dimensions: 16 × 116 × 110 mm
 - Operating Ambient Temperature: –20 ° C to +60 ° C
 - Suitable for Connected Field Devices and Hazardous Areas: Valve positioners, electrical converters, and other intrinsically safe equipment. Zones 0, 1, 2; IIA, IIB, IIC hazardous areas.
- ExplosionProof Rating Marking: [Exia Ga] IIC

Model Selection and Specifications

➤ Model and Code Structure

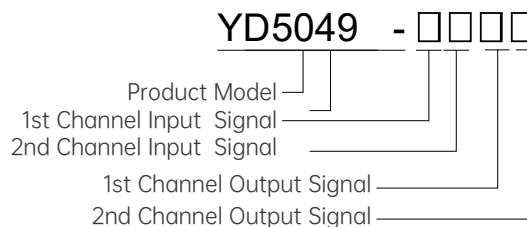
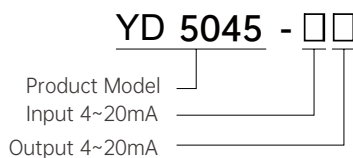

➤ Model and Code Structure

Input	Code
4~20mA	A

Output	Code
4~20mA	A

Wiring Diagram

Terminal Wiring: Use solid or stranded wire with a cross section of 0.5 ~ 2.5 mm².

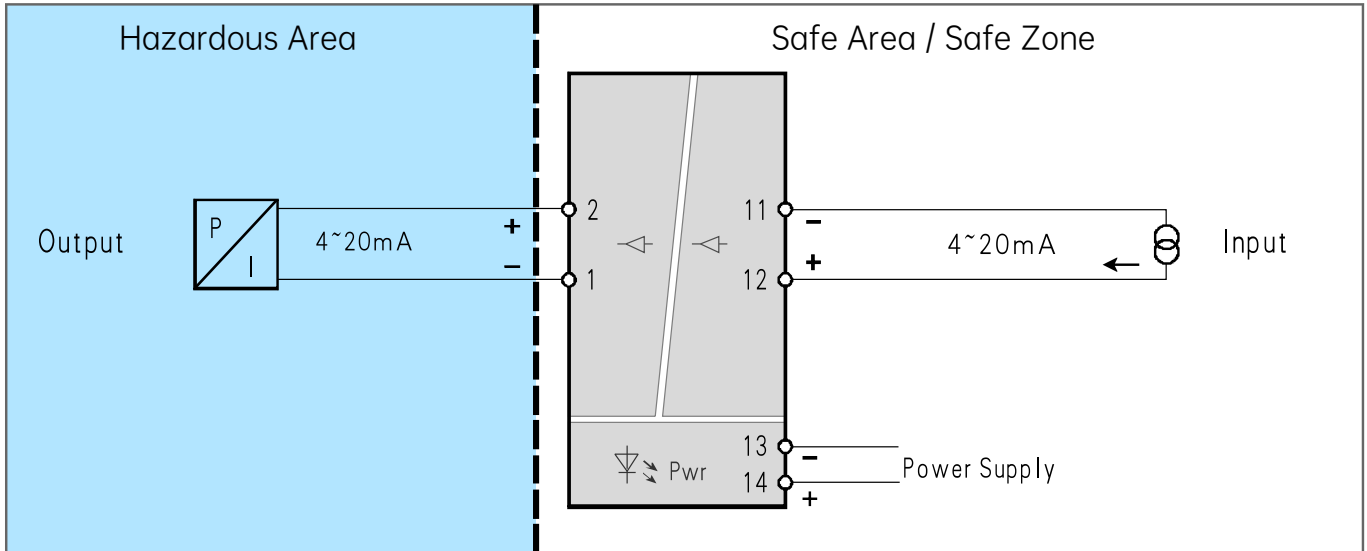

YD5045 Terminal Wiring Diagram

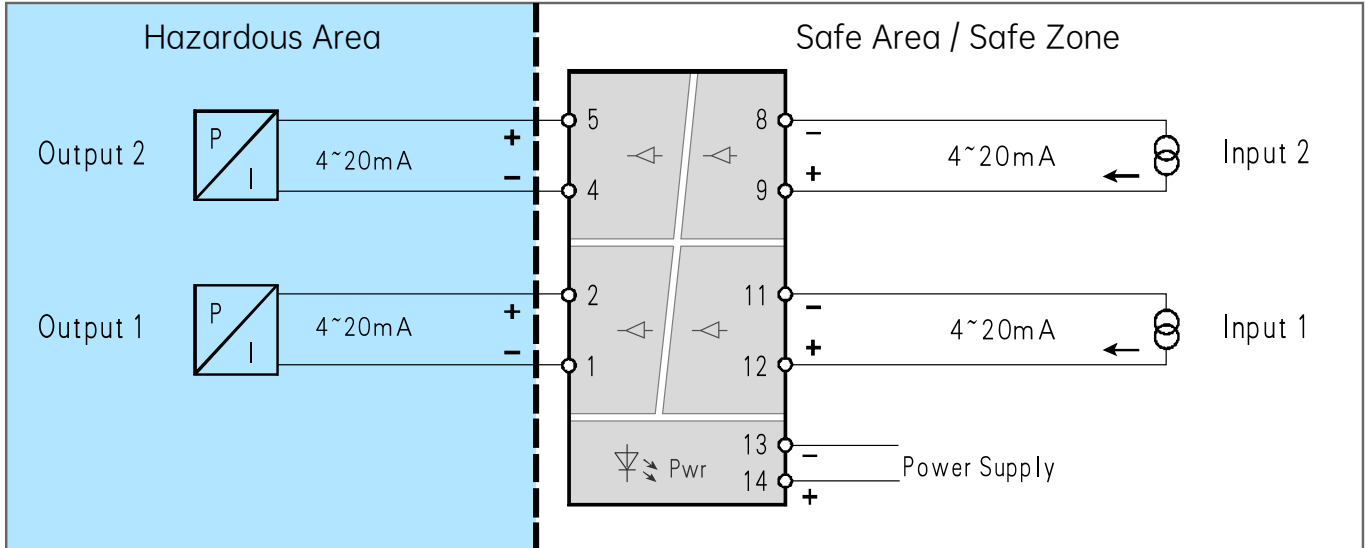

YD5049 Terminal Wiring Diagram

Thermocouple Input Isolating Safety Barrier

Overview

Suitable for thermocouple signal inputs from field hazardous areas. After isolation, the signal is converted into a standard DC signal for control systems or other instruments.

Features

- ▶ Powered by an independent DC power supply, with isolation between the power supply, input, and output.
- ▶ Standard 35mm DIN rail clip-on mounting. Plugin terminal blocks with spring-loaded connections.

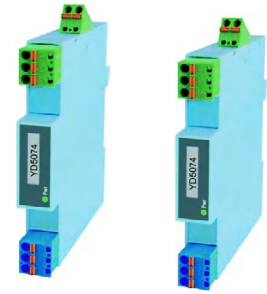

YD5074
[1 In, 1 Out]

Technical Specifications

- ▶ Power Supply
 - Supply Voltage Range: 20–30 VDC
 - Rated Supply Voltage: 24 VDC
 - Current Consumption (at 24 VDC): < 30 mA
- ▶ Input from Hazardous Area
 - Input Thermocouple Types: K, E, S, B, R, T, N, W, J, and other thermocouple types
- ▶ Output to Safe Area
 - Output Current: 4–20 mA; other specified currents
 - Output Voltage: 1–5 V; other specified voltages
 - Load Resistance:
 - For 4–20 mA output: $\leq 350 \Omega$ (factory default)
 - For 1–5 V output: $\geq 100 \Omega$
- ▶ General Parameters
 - Standard Accuracy: $\pm 0.2\%$
 - Temperature Drift: Basic error / 10°C
 - Response Time: < 10 ms
 - Isolation Capability: 2.5 kV between input/output power, 1 min, 50 Hz
 - Insulation Resistance: $\geq 100 \text{ M}\Omega$ / 500 VDC between input/output power
 - Enclosure Material: PC (polycarbonate)
 - Dimensions: 16 × 116 × 110 mm
 - Operating Ambient Temperature: -20°C to $+60^\circ \text{C}$
 - Suitable for Connected Field Devices and Hazardous Areas: Thermocouple or millivolt signal sensors. Zones 0, 1, 2; IIA, IIB, IIC hazardous areas.
- ▶ ExplosionProof Rating Marking: [Exia Ga] IIC

Model Selection and Specifications

▶ Model and Code Structure

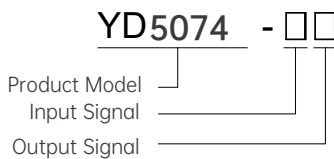

▶ Code

Input	Code
Thermocouple K; E; S; B; R; T; N; W; J (Temperature Range)	F

Output			
Current Signal	Code	Voltage Signal	Code
4~20mA	A	1~5V	1
0~20mA	B	0~5V	2
0~10mA	C	0~10V	3
Designated Current	Z	Designated Voltage	9

Thermocouple Types, Ranges, and Measurement Error Table:

Type	Temperature Range ($^\circ \text{C}$)	Minimum Range ($^\circ \text{C}$)	Absolute Error	Basic Error	
热 电 偶	K	0~1300	120	$\pm 1^\circ \text{C}$	$\pm 0.2\%$
	E	0~1000	80	$\pm 1^\circ \text{C}$	$\pm 0.2\%$
	S	0~1600	580	$\pm 2^\circ \text{C}$	$\pm 0.2\%$
	B	400~1800	1000	$\pm 2^\circ \text{C}$	$\pm 0.2\%$
	R	0~1600	850	$\pm 2^\circ \text{C}$	$\pm 0.2\%$
	T	-200~400	120	$\pm 1^\circ \text{C}$	$\pm 0.2\%$
	N	0~1200	180	$\pm 1^\circ \text{C}$	$\pm 0.2\%$
	W	0~2300	340	$\pm 2^\circ \text{C}$	$\pm 0.2\%$
	J	0~1200	100	$\pm 1^\circ \text{C}$	$\pm 0.2\%$

Note:

1. The basic error and absolute error listed in the table shall be applied by taking the larger value between the basic error and the absolute error.

2. Cold junction compensation error for thermocouple input: $\pm 1^\circ \text{C}$.

Wiring Diagram

Terminal Wiring: Use solid or stranded wire with a crossection of 0.5 ~ 2.5 mm².

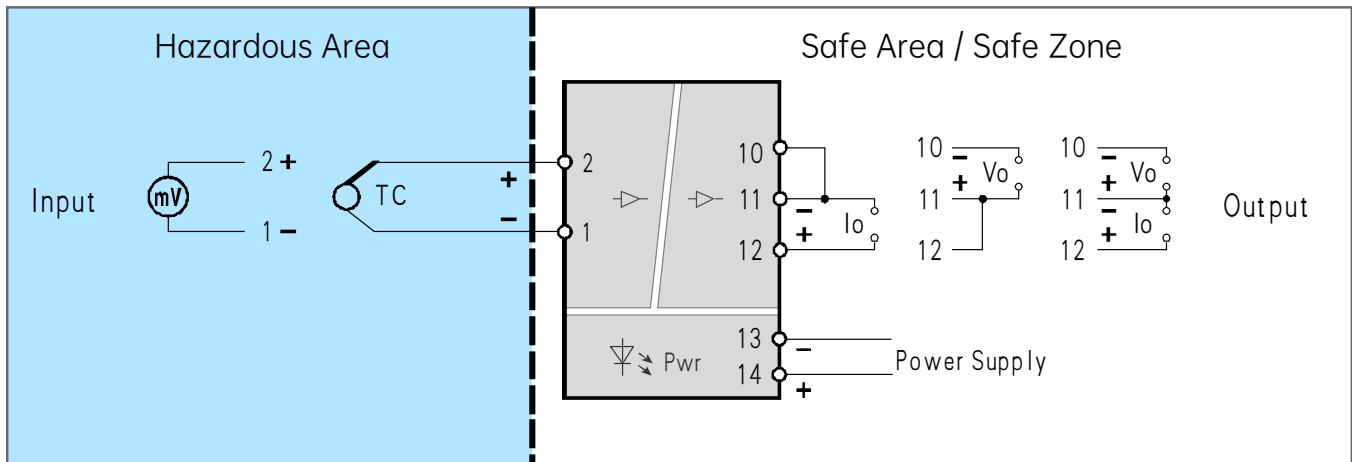

YD5074 Terminal Wiring Diagram

Example of Model Selection and Explanation:

Taking YD5074FA (K, 0–1000° C) as an example:

This is a thermocouple input isolating safety barrier with Class 0.2 accuracy, 35mm DIN rail clipon mounting. The hazardous area input signal is a Ktype thermocouple, and the safe area output is 4–20mA corresponding to 0–1000° C.

Thermocouple Input Isolating Safety Barrier

Overview

Suitable for thermocouple signal inputs from field hazardous areas. After isolation, the signal is converted into a standard DC signal for control systems or other instruments.



YD5082
[1 In, 1 Out]

Features

- Powered by an independent DC power supply, with isolation between the power supply, input, and output.
- Standard 35mm DIN rail clip on mounting. Plug-in terminal blocks with springloaded connections.

Technical Specifications

- Power Supply
 - Supply Voltage Range: 20–30 VDC
 - Rated Supply Voltage: 24 VDC
 - Current Consumption (at 24 VDC): <25mA
- Input from Hazardous Area
 - Input Thermal Resistor Pt100; Pt10; Cu50; Cu100 and other types (of thermal resistors)
 - Resistor (Permissible Lead Resistance: ≤ 5Ω per wire)
- Output to Safe Area
 - Output Current: 4–20 mA; other specified currents
 - Output Voltage: 1–5 V; other specified voltages
 - Load Resistance:
 - For 4–20 mA output: ≤ 350 Ω (factory default)
 - For 1–5 V output: ≥ 100 kΩ
- General Parameters
 - Standard Accuracy: ±0.1%
 - Temperature Drift: Basic error / 10 °C
 - Response Time: < 10 ms
 - Isolation Capability: 2.5 kV between input/output power, 1 min, 50 Hz
 - Insulation Resistance: ≥ 100 MΩ / 500 VDC between input/output power
 - Enclosure Material: PC (polycarbonate)
 - Dimensions: 16 × 116 × 110 mm
 - Operating Ambient Temperature: –20 °C to +60 °C
 - Suitable for Connected Field Devices and Hazardous Areas: Thermocouple or millivolt signal sensors. Zones 0, 1, 2; IIA, IIB, IIC hazardous areas.
- ExplosionProof Rating Marking: [Exia Ga] IIC

Model Selection and Specifications

- Model and Code Structure

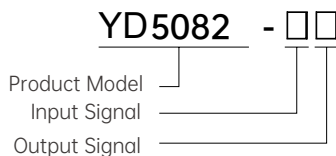

- Code

Input	Code
Thermal Resistor Pt100; Pt10; Cu50; Cu100 (Temperature Range)	F

Thermal Resistor Type, Range & Error Table

Type	Temperature Range (°C)	Minimum Range (°C)	Absolute Error	Basic Error
Pt100	-200~800	50	±0.2	±0.1
Pt10	-200~800	200	±0.4	±0.1
Cu50	-50~150	50	±0.4	±0.1
Cu100	-50~150	50	±0.4	±0.1

Thermal resistor index numbers not listed in this table can also be specified when placing an order. For the basic error and absolute error listed in the table, the larger value between the two shall be adopted in application.

Wiring Diagram

Terminal Wiring: Use solid or stranded wire with a cross-section of 0.5 ~ 2.5 mm².

Selection Example and Explanation:

Selection Example and Explanation:

Taking YD5082FA (Pt100, 0–200° C) as an example:

This is a resistance temperature detector (RTD) input isolating safety barrier with Class 0.1 accuracy and 35mm DIN rail clipon mounting. The hazardous area input signal is a Pt100 RTD, and the safe area output is 4–20mA corresponding to 0–200° C.

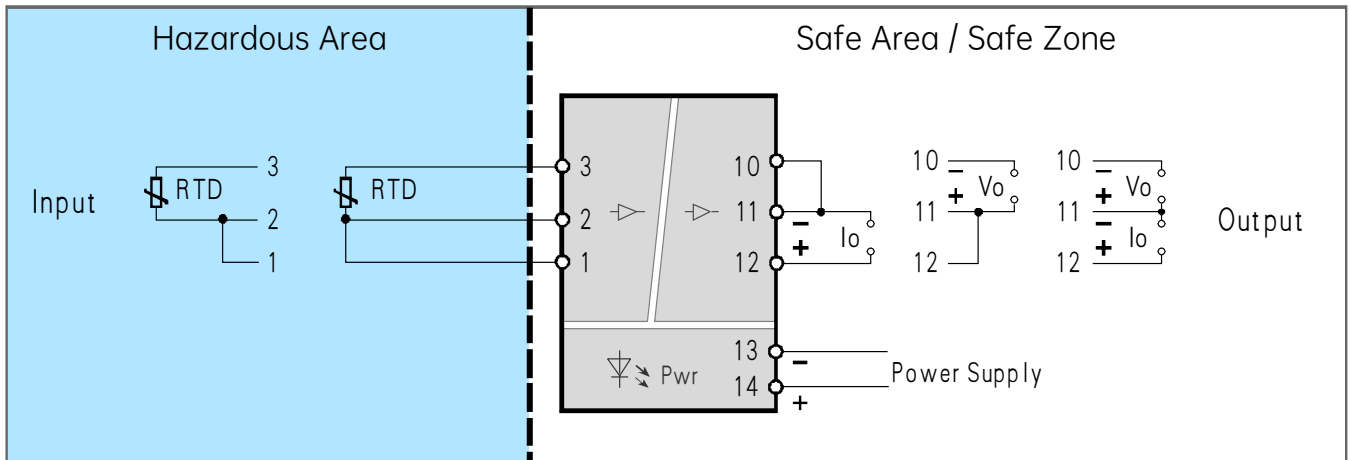

YD5082 Terminal Wiring Diagram

General Purpose Current Vector Inverter

Overview

The AF10 series inverter adopts internationally advanced current vector control technology, delivering rated torque at low speeds, ultraquiet and stable operation, diverse control modes, up to 36 comprehensive protection and alarm functions, multiple parameters for online monitoring and adjustment, a builtin RS485 communication interface, flexible operation, and can meet a wide range of user requirements to the greatest extent.



Application Areas

The AF10 series inverter offers stable operation, high precision, and excellent reliability. Its diverse parameters can adapt to different motors and industry needs, and it is widely used in machine tools, textiles, plastic machinery, food processing, cement, printing and dyeing, metallurgy, steel, and other industries.

Features

- Supports both openloop and closedloop control of asynchronous motors.
- Enables precise control of torque, speed, and position for asynchronous motors.
- Through I/O expansion, it can achieve 12 digital inputs and 7 digital outputs; 2 analog inputs and 2 analog outputs.
- With a highcostperformance PLC card, it can be programmed to implement process control for small to mediumsized equipment, greatly enhancing the value for system integrators and field engineers.
- **Starting torque greater than 150%**

using automatic torqueboost technology, it can provide over 150% torque at 0.5 Hz under openloop control, enabling smooth loaded startup.

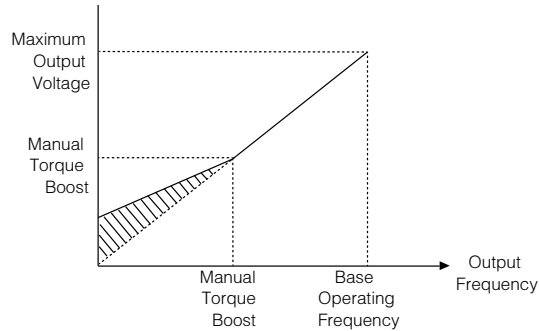
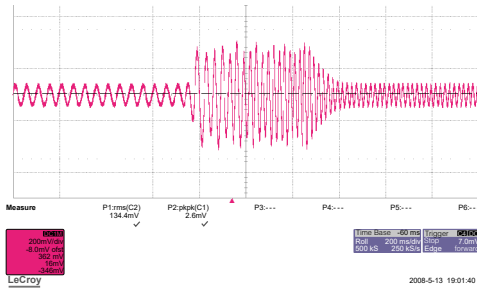

- **Openloop speed accuracy better than 1.0%**

Using dynamic slip control technology, the speed accuracy in openloop control is better than 1.0%, maintaining constant speed even under frequent load variations.

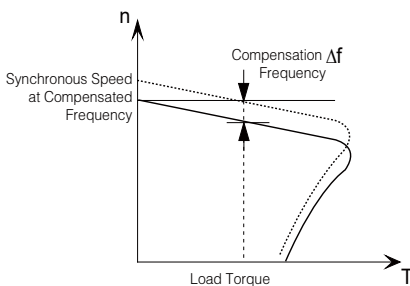

- **Loadstepchange tripfree control technology**

By employing automatic currentlimiting technology and automatic frequency regulation technology, the inverter can maintain torque output capability during sudden load changes, ensuring continuous equipment operation without tripping.

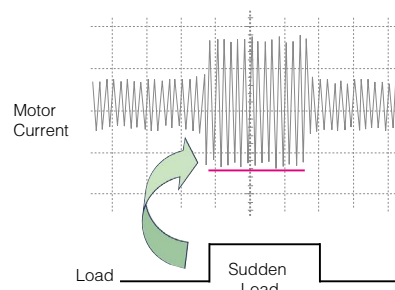

Technical Specifications

Item	Specification
Rated Input Voltage / Frequency	Single phase: 200–240 V, 50/60 Hz; Threephase: 380–440 V, 50/60 Hz
Rated Input Voltage / Frequency	Single phase: 176–264 V, frequency within $\pm 5\%$; Threephase: 304–456 V, frequency within $\pm 5\%$
Rated Output Voltage	0 – rated input voltage
Overload Current (max)	Gtype: 150 % for 1 minute, 180 % for 20 seconds; Ptype: 120 % for 1 minute, 150 % for 1 second
Control Method	Current vector control
Frequency Control Range	Low frequency mode: 0.00 – 650.0 Hz; High frequency mode: 0.0 – 1000 Hz (reserved)
Frequency Accuracy	Digital command: $\pm 0.01\%$ ($-10\text{ }^{\circ}\text{C}$ to $+40\text{ }^{\circ}\text{C}$); Analog command: $\pm 0.1\%$ (at $25\text{ }^{\circ}\text{C}$)
Set Frequency Resolution	Digital command: 0.01 Hz; Analog command: 1/1000 of maximum frequency
Digital command: 0.01 Hz; Analog command: 1/1000 of maximum frequency	0.01Hz
Frequency Setting Signal	0 ~ 10V, 0 ~ 20mA
Acceleration/Deceleration Time	0.1 – 3600.0 seconds (accel./decel. times can be set independently)
Braking Torque	Up to 150 % with external braking resistor
Voltage/Frequency Characteristic	4 fixed V/F curves selectable, plus arbitrary V/F curve setting
Protection Functions	Overvoltage, undervoltage, current limit, overcurrent, overload, electronic thermal relay, overtemperature, overvoltage stall, load shortcircuit, ground fault, undervoltage protection, input phase loss, output phase loss, ground/shortcircuit between phases, motor overload protection, etc.
Operating Ambient Temperature	$-10\text{ }^{\circ}\text{C}$ ~ $+40\text{ }^{\circ}\text{C}$
Humidity	5 – 95 % RH (noncondensing)
Storage Temperature	$-40\text{ }^{\circ}\text{C}$ ~ $+70\text{ }^{\circ}\text{C}$
Use Location	Indoors (free of corrosive gases)
Installation Location	Altitude ≤ 1000 m (derating required above 1000 m), dustfree, no corrosive gases, no direct sunlight
Vibration	$< 5.9\text{ m/s}^2$ (0.6 g)
Protection Rating	IP20

Model Selection and Specification

Series	Model	Input Power	Power Capacity (kVA)	Input Current (A)	Output Current (A)	Matched Motor (kW)
AF10	S2R04GB	Single phase 220V 50/60Hz Voltage Range: 176 – 264 V Frequency Imbalance: < ±10 %	1	5.1	2.4	0.4
	S2R07GB		1.7	9.2	4.5	0.75
	S21R5GB		2.8	13.1	7.0	1.5
	S22R2GB		4	23	10.0	2.2
	3R75GB/31R5PB	Three phase 380V 50/60Hz Voltage Range: 304 – 456 V Voltage Imbalance: < 5% Frequency Imbalance: < ±10%	1.6/3.2	3.7/5.4	2.5/4	0.75/1.5
	31R5GB/32R2PB		3.2/4.8	5.4/7	4/6	1.5/2.2
	32R2GB/3004PB		4.8/6	7/10.7	6/9	2.2/3.7
	3004GB/35R5PB		4/8.6	10.7/15.5	9/13	4/5.5
	35R5GB/37R5PB		8.6/11.2	15.5/20.5	13/17	5.5/7.5
	37R5GB/3011PB		11.2/17	20.5/26	17/25	7.5/11
	3011GB/3015PB		17/21	26/35	25/32	11/15
	3015GB/3018PB		21/24	35/38.5	32/37	15/18.5
	3018GB/3022PB		24/30	38.5/46.5	37/45	18/22
	3022G/3030P		30/40	46.5/62	45/60	22/30
	3030G/3037P		40/50	62/76	60/75	30/37
	3037G/3045P		50/60	76/92	75/90	37/45
	3045G/3055P		60/72	92/113	90/110	45/55
	3055G/3075P		72/100	113/157	110/150	55/75
	3075G/3093P		100/116	157/180	150/176	75/93
	3093G/3110P		116/138	180/214	176/210	93/110
3110G/3132P	138/167	214/256	210/250	110/132		
3132G/3160P	167/200	256/307	253/304	132/160		
3160G/3185P	200/230	307/350	304/342	160/185		

Dimensions

Specifications	H	W	D1	D2
S2R04GB~S2R07GB(Two mounting holes)	172	84.5	129	141
S21R5GB~S2004GB	194	97	143	154
3R75GB/31R5PB~3004GB/35R5PB	185	118	157	166
35R5GB/37R5PB~37R5GB/3011PB	246	160	172	187
3011GB/3015PB~3018GB/3022PB	322	220	197	210
3022G/3030P~3037G/3045P	430	256	207	220
3045G/3045P~3055G/3075P	564	309	265	278
3075G/3093P~3110G/3132P	600	360	290	303
3132G/3160P~3160G/3185P	780	480	310	323

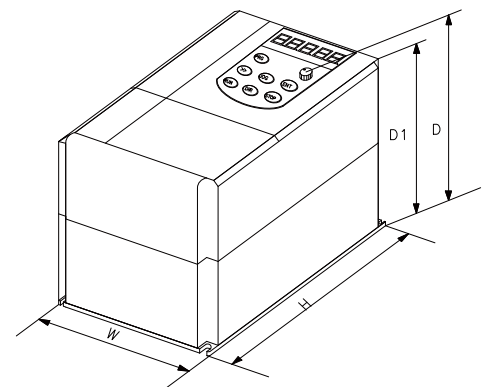

Overall Dimensions (Unit: mm)

Continually Strive for Excellence

Telephone / WhatsApp: +852 - 2770 8785

Web : www.yudian.com www.yudian.com.hk

E- mail : sales@yudian.com.hk

YUDIAN AUTOMATION TECHNOLOGY CO.,LTD.

- 12/F, Chun Hoi Commercial Building, 688 Shanghai Street, Mong Kok, Kowloon, Hong Kong.
- 17 Huoju Road North, Huoju Hi-tech District, Xiamen, Fujian, China.
- 6 Longku Road East, Xiang'an District, Xiamen, Fujian, China.
- 35th Floor, Great China International Trade Plaza, Futian District, Shenzhen, China.